



Developer Note

---

# Macintosh LC 575 Computer



Developer Press  
© Apple Computer, Inc. 2000

🍏 Apple Computer, Inc.  
© 1994, Apple Computer, Inc.  
All rights reserved.

No part of this publication may be reproduced, stored in a retrieval system, or transmitted, in any form or by any means, mechanical, electronic, photocopying, recording, or otherwise, without prior written permission of Apple Computer, Inc. Printed in the United States of America.

The Apple logo is a registered trademark of Apple Computer, Inc. Use of the "keyboard" Apple logo (Option-Shift-K) for commercial purposes without the prior written consent of Apple may constitute trademark infringement and unfair competition in violation of federal and state laws.

No licenses, express or implied, are granted with respect to any of the technology described in this book. Apple retains all intellectual property rights associated with the technology described in this book. This book is intended to assist application developers to develop applications only for Apple Macintosh computers.

Apple Computer, Inc.  
20525 Mariani Avenue  
Cupertino, CA 95014  
408-996-1010

Apple, the Apple logo, APDA, AppleLink, LaserWriter, Macintosh, Macintosh Quadra, and PowerBook are trademarks of Apple Computer, Inc., registered in the United States and other countries.

AppleCD, AppleColor, Apple Desktop Bus, Apple SuperDrive, Finder, Macintosh Centris, PlainTalk, and QuickDraw are trademarks of Apple Computer, Inc.

Adobe Illustrator and PostScript are trademarks of Adobe Systems Incorporated, which may be registered in certain jurisdictions.

America Online is a service mark of Quantum Computer Services, Inc.

CompuServe is a registered service mark of CompuServe, Inc.

FrameMaker is a registered trademark of Frame Technology Corporation.

Helvetica and Palatino are registered trademarks of Linotype Company.

Internet is a trademark of Digital Equipment Corporation.

ITC Zapf Dingbats is a registered trademark of International Typeface Corporation.

Motorola is a registered trademark of Motorola Corporation.

NuBus is a trademark of Texas Instruments.

Trinitron is a trademark of Sony Corporation.

Simultaneously published in the United States and Canada.

#### **LIMITED WARRANTY ON MEDIA AND REPLACEMENT**

**If you discover physical defects in the manual or in the media on which a software product is distributed, APDA will replace the media or manual at no charge to you provided you return the item to be replaced with proof of purchase to APDA.**

**ALL IMPLIED WARRANTIES ON THIS MANUAL, INCLUDING IMPLIED WARRANTIES OF MERCHANTABILITY AND FITNESS FOR A PARTICULAR PURPOSE, ARE LIMITED IN DURATION TO NINETY (90) DAYS FROM THE DATE OF THE ORIGINAL RETAIL PURCHASE OF THIS PRODUCT.**

**Even though Apple has reviewed this manual, APPLE MAKES NO WARRANTY OR REPRESENTATION, EITHER EXPRESS OR IMPLIED, WITH RESPECT TO THIS MANUAL, ITS QUALITY, ACCURACY, MERCHANTABILITY, OR FITNESS FOR A PARTICULAR PURPOSE. AS A RESULT, THIS MANUAL IS SOLD "AS IS," AND YOU, THE PURCHASER, ARE ASSUMING THE ENTIRE RISK AS TO ITS QUALITY AND ACCURACY.**

**IN NO EVENT WILL APPLE BE LIABLE FOR DIRECT, INDIRECT, SPECIAL, INCIDENTAL, OR CONSEQUENTIAL DAMAGES RESULTING FROM ANY DEFECT OR INACCURACY IN THIS MANUAL, even if advised of the possibility of such damages.**

**THE WARRANTY AND REMEDIES SET FORTH ABOVE ARE EXCLUSIVE AND IN LIEU OF ALL OTHERS, ORAL OR WRITTEN, EXPRESS OR IMPLIED. No Apple dealer, agent, or employee is authorized to make any modification, extension, or addition to this warranty.**

**Some states do not allow the exclusion or limitation of implied warranties or liability for incidental or consequential damages, so the above limitation or exclusion may not apply to you. This warranty gives you specific legal rights, and you may also have other rights which vary from state to state.**

# Contents

	Figures and Tables	vii
Preface	About This Note	ix
	Contents of This Note	ix
	Supplementary Documents	x
	Conventions and Abbreviations	xi
	Typographical Conventions	xi
	Special Elements	xi
	Standard Abbreviations	xi
Chapter 1	Introduction	1
	Features	2
	Design of the Computer	3
	Views of the Computer	4
	Access to the Logic Board	4
	Built-in Color Display	5
	Front Panel Push Buttons	6
	Screen Control Push Buttons	6
	Sound Control Push Buttons	6
	Power On and Off	6
	Power Saver	7
	RAM Expansion	7
	RAM SIMMs	8
	Video RAM	12
	SCSI Bus	13
	SCSI Connectors	13
	SCSI Bus Termination	14
	Comparison of SCSI Arrangements	15
	Floppy Disk Drive	15
	Serial I/O Ports	16
	Communications Options	17
	ADB Ports	17
	Sound	18
	Sound Inputs	18
	Built-in Microphone	18
	Sound Input Jack	18
	Sound Outputs	19
	Built-in Speakers	19
	Sound Output Jacks	19

Sound Modes	19
Sample Rates	20
Keyboard	20
Expansion Slot	21

---

Chapter 2      **Architecture**      23

---

Block Diagram and ICs	24
Microprocessor	24
Custom ICs	26
MEMCjr IC	26
PrimeTime IC	26
DFAC II IC	27
Cuda IC	28
Antelope IC	28
Address Maps	28
RAM Addresses	30
Video RAM Addresses	30
Expansion Card Addresses	30
Video Display Parameters	30

---

Chapter 3      **Software**      33

---

ROM Software	34
Modularity	34
Machine Identification	34
New Memory Controller	35
New Memory Maps	35
New Video ICs	35
New Sound IC and Primitives	35
ADB and Power Management	35
Push Button Interrupts	36
Power Saver Software	36
System Software	36
System Enabler	37
Booting From a CD-ROM	37
Enhanced QuickDraw	37
New Control Panels	37
Sound Control Panel	37
Screen Control Panel	40
Screen Driver	40
Screen Driver Calls	41

Chapter 4	<b>Expansion</b>	45
	Expansion Slot	46
	Pin Assignments	46
	Signal Descriptions	48
	Compatibility With Older Cards	51
	Expansion Card	51
	Mechanical Design	51
	Card Connectors	52
	Power for the Card	52
	Address Space	52
	Bus Master on a Card	53

Chapter 5	<b>Internal Storage Devices</b>	55
	Storage Device Slide-In Bays	56
	Internal CD-ROM Drive	58
	Dimensions of the CD-ROM Drive	59
	Mounting Method for the CD-ROM Drive	60
	Power for the CD-ROM Drive	60
	Internal CD-ROM Integration	61

Appendix	<b>AppleCD 300i Plus</b>	63
	General	63
	Specifications	63

	<b>Index</b>	65
--	--------------	----

	<b>Foldouts</b>	69
--	-----------------	----



# Figures and Tables

Chapter 1	Introduction	1	
	<b>Figure 1-1</b>	Front view of the Macintosh LC 575 computer	4
	<b>Figure 1-2</b>	Back view of the Macintosh LC 575 computer	5
	<b>Figure 1-3</b>	Screen control panel	7
	<b>Figure 1-4</b>	RAM configurations	8
	<b>Figure 1-5</b>	RAM expansion SIMM	9
	<b>Table 1-1</b>	Comparison of the Macintosh LC 575 with the Macintosh LC 520 and Macintosh LC 475 computers	3
	<b>Table 1-2</b>	Signal assignments on the RAM SIMM socket	10
	<b>Table 1-3</b>	Amount of VRAM and pixel depths supported	13
	<b>Table 1-4</b>	Pin assignments for the internal and external SCSI connectors	14
	<b>Table 1-5</b>	Pin assignments for the internal floppy disk connector	16
	<b>Table 1-6</b>	Serial port signals	17
	<b>Table 1-7</b>	ADB connector pin assignments	18
	<b>Table 1-8</b>	Reset and NMI key combinations	20
Chapter 2	Architecture	23	
	<b>Figure 2-1</b>	Block diagram of the Macintosh LC 575 computer	25
	<b>Figure 2-2</b>	Simplified 24-bit and 32-bit address maps	29
	<b>Figure 2-3</b>	Video timing diagram	32
	<b>Table 2-1</b>	Video timing parameters	31
Chapter 3	Software	33	
	<b>Figure 3-1</b>	Sound control panel showing alert sounds	38
	<b>Figure 3-2</b>	Dialog box for adding a sound	38
	<b>Figure 3-3</b>	Sound control panel showing sound in I	39
	<b>Figure 3-4</b>	Sound input options	39
	<b>Figure 3-5</b>	Screen control panel	40
Chapter 4	Expansion	45	
	<b>Figure 4-1</b>	Generating the card select signal	53
	<b>Table 4-1</b>	Pin assignments for the expansion connector	47
	<b>Table 4-2</b>	Expansion connector signal descriptions	49
	<b>Table 4-3</b>	Power available for the expansion card	52

<b>Figure 5-1</b>	Installation of the internal CD-ROM drive	57
<b>Figure 5-2</b>	Connector locations on the CD-ROM drive	57
<b>Figure 5-3</b>	Connector locations on the hard disk drive	58
<b>Figure 5-4</b>	Dimensions of the CD-ROM drive	59
<b>Figure 5-5</b>	The AppleCD 300i CD-ROM drive mounted on the sled	60
<b>Figure 5-6</b>	Pins on the internal CD-ROM audio connector	61
<b>Table 5-1</b>	Power provided for the AppleCD 300i CD-ROM drive	60

<b>Table A-1</b>	AppleCD 300i Plus specifications	63
------------------	----------------------------------	----

### Foldouts 69

---

<b>Foldout 1</b>	Expansion card design guide
<b>Foldout 2</b>	Expansion card component height restrictions
<b>Foldout 3</b>	Expansion card assembly guide



# About This Note

---

This developer note provides information about the Macintosh LC 575 computer, a desktop Macintosh model with an MC68LC040 microprocessor. The Macintosh LC 575 has an integrated design with a built-in 14-inch color display and CD-ROM drive (optional).

This developer note is intended primarily for hardware engineers who are experienced Macintosh developers and who wish to create products that are compatible with the computer described in the note.

**Note**

To make effective use of the information in this developer note, you should already be familiar with the general technology of Macintosh computers. If you are not, or if you would like more information, you may wish to obtain copies of the related technical documents listed in “Supplementary Documents,” later in this preface. ♦

## Contents of This Note

---

The information is arranged in five chapters, an appendix, an index, and a set of mechanical drawings:

- Chapter 1, “Introduction,” gives a summary of the features and a general description of the Macintosh LC 575 computer.
- Chapter 2, “Architecture,” describes the internal organization of the computer. It includes a block diagram and descriptions of the integrated circuits that are specific to this computer.
- Chapter 3, “Software,” summarizes the new features of the ROM software and the system software.
- Chapter 4, “Expansion,” describes the I/O expansion slot and gives guidelines for designing an expansion card to plug into it.
- Chapter 5, “Internal Storage Devices,” describes the mass storage devices installed inside the computer.
- An appendix, “AppleCD 300i Plus,” gives the specifications for the internal CD-ROM drive used in the Macintosh LC 575 computer.
- “Foldouts,” at the end of the note, contains 11-by-17-inch foldout pages with mechanical drawings for the expansion card.

## Supplementary Documents

---

To supplement the information in this developer note, you should have copies of the appropriate Apple reference books, including *Inside Macintosh: Overview*; *Inside Macintosh: Devices*; *Guide to the Macintosh Family Hardware*, second edition; and *Designing Cards and Drivers for the Macintosh Family*, third edition. These books are available in technical bookstores and through APDA.

The Macintosh LC 575 computer shares some features with two earlier models:

- the Macintosh LC 520, described in *Macintosh Developer Note Number 4*, APDA catalog number R0528LL/A
- the Macintosh LC 475, described in *Macintosh Developer Note Number 6*, APDA catalog number R0550LL/A

Developer notes for the individual models are also on the Reference Library Editions of the developer CD-ROMs.

APDA is Apple's worldwide source for over three hundred development tools, technical resources, training products, and information for anyone interested in developing applications on Apple platforms. Customers receive the quarterly *APDA Tools Catalog* featuring all current versions of Apple development tools and the most popular third-party development tools. Ordering is easy; there are no membership fees, and application forms are not required for most products. APDA offers convenient payment and shipping options, including site licensing.

To order products or to request a complimentary copy of the *APDA Tools Catalog*, contact

APDA  
 Apple Computer, Inc.  
 P.O. Box 319  
 Buffalo, NY 14207-0319

Telephone	800-282-2732 (United States) 800-637-0029 (Canada) 716-871-6555 (International)
Fax	716-871-6511
AppleLink	APDA
America Online	APDA
CompuServe	76666,2405
Internet	APDA@applelink.apple.com

## Conventions and Abbreviations

---

This developer note uses the following typographical conventions and abbreviations.

### Typographical Conventions

---

Computer-language text—any text that is literally the same as it appears in computer input or output—appears in `Courier` font.

Hexadecimal numbers are preceded by a dollar sign (\$). For example, the hexadecimal equivalent of decimal 16 is written as \$10.

### Special Elements

---

This developer note has three kinds of special paragraphs: Note, Important, and Warning.

#### Note

A note like this contains information that is interesting but not essential for an understanding of the text. ◆

#### IMPORTANT

A note like this contains important information that you should read before proceeding. ▲

#### ▲ WARNING

A note like this directs your attention to something that could cause damage or result in a loss of data. ▲

### Standard Abbreviations

---

When unusual abbreviations appear in this book, the corresponding terms are also spelled out. Standard units of measure and other widely used abbreviations are not spelled out. Here are the standard units of measure used this developer note:

A	amperes	kg	kilograms
dB	decibels	kHz	kilohertz
Hz	hertz	kΩ	kilohms
in.	inches	lb.	pounds
K	1024	mA	milliamperes
KB	kilobytes	μA	microamperes

## P R E F A C E

MB	megabytes	$\mu$ s	microseconds
Mbit	megabits	sec.	seconds
MHz	megahertz	V	volts
min.	minutes	W	watts
mm	millimeters	$\Omega$	ohms
ms	milliseconds		

Here are other abbreviations used in this developer note:

$\$n$	hexadecimal value $n$
AC	alternating current
A/D	analog to digital
ADB	Apple Desktop Bus
AGC	automatic gain control
AUI	auxiliary unit interface
CD	compact disc
CD-ROM	compact-disc read-only memory
CLUT	color lookup table
CMOS	complementary metal-oxide semiconductor
CPU	central processing unit
DAC	digital-to-analog converter
DC	direct current
DIN	Deutsche Industrie Normal
dpi	dots per inch
FPU	floating-point unit
IC	integrated circuit
I/O	input/output
JEDEC	Joint Electron Device Engineering Council
MMU	memory management unit
MOS	metal-oxide semiconductor
NMI	nonmaskable interrupt
PDS	processor-direct slot
PRAM	parameter RAM
PWM	pulse-width modulation
RAM	random-access memory
RMS	root-mean-square
ROM	read-only memory
SCC	Serial Communications Controller
SCSI	Small Computer System Interface

## P R E F A C E

SIMM	Single Inline Memory Module
SWIM	Super Woz Integrated Machine (a custom IC that controls the floppy disk interface)
TTL	transistor-transistor logic (used as a standard for IC device loads)
VLSI	very large scale integration
VRAM	video RAM



# Introduction

---

The Macintosh LC 575 computer adds the power of the MC68040 microprocessor to an integrated design with a built-in color display like that of the Macintosh LC 520. This chapter outlines the main features of the Macintosh LC 575 computer and describes its appearance and external features.

## Features

---

Here is a summary of the hardware features of the Macintosh LC 575 computer (individual features are described in the sections that follow):

- Motorola MC68LC040 microprocessor (no FPU) running at 33 MHz
- installed RAM capacity of 4 MB, expandable to 36 MB
- 1 MB ROM soldered to main logic board
- built-in video hardware using separate video RAM
- built-in 14-inch Trinitron<sup>®</sup> color display
- internal hard disk with 160 MB or 320 MB capacity, using the internal SCSI connector; external SCSI port for additional SCSI devices
- optional internal CD-ROM drive
- internal high-density floppy disk drive with 1.4 MB capacity
- standard Macintosh I/O ports: two serial ports, two sound output jacks, a SCSI port, and an ADB port
- internal communications port; can provide either a modem or an Ethernet interface
- sound input jack
- built-in microphone and front panel headphone jack
- two internal speakers, for stereo sound
- push buttons on the front panel to control sound volume and display intensity
- power on and off from the keyboard
- Power Saver mode so that software can turn off the built-in display monitor when the machine is unused for a set period of time
- expansion slot for 96-pin or 114-pin expansion cards (accepts PDS cards designed for the Macintosh LC series; not directly connected to the MC68LC040 processor)

Whereas the mechanical design of the Macintosh LC 575 computer is like that of the Macintosh LC 520, its electrical design is similar to that of the Macintosh LC 475.

Table 1-1 compares the features of all three computers.



## Introduction

**Table 1-1** Comparison of the Macintosh LC 575 with the Macintosh LC 520 and Macintosh LC 475 computers

Feature	Macintosh LC 520	Macintosh LC 475	Macintosh LC 575
Processor type	MC68030	MC68LC040	MC68LC040
Processor speed	25 MHz	25 MHz	33 MHz
Amount of RAM	4 MB–36 MB	4 MB–36 MB	4 MB–36 MB
RAM expansion	1 SIMM	1 SIMM	1 SIMM
Video display	Built-in 14" color display	External video monitor	Built-in 14" color display
Amount of VRAM	512 KB–768 KB	512 KB–1 MB	512 KB–1 MB
Microphone	Built in	External	Built in
Speakers	2	1	2
Sound capabilities	8 bits/channel; mono in, mono record, stereo out	8 bits/channel; stereo in, mono record, stereo out	8 bits/channel; mono in, mono record, stereo out
Floppy disk drive	1 internal	1 internal	1 internal
ADB ports	2	1	1
Internal SCSI drives	2 (hard disk, CD-ROM)	1 (hard disk)	2 (hard disk, CD-ROM)
External SCSI ports	1	1	1
Ethernet	No	No	Optional, internal
Expansion slots	1 PDS slot (compatible with Macintosh LC series PDS cards)	1 I/O slot (compatible with Macintosh LC series PDS cards)	1 I/O slot (compatible with Macintosh LC series PDS cards)

## Design of the Computer

---

The Macintosh LC 575 computer has an integrated design like that of the Macintosh LC 520, with a built-in 14-inch Trinitron color display and front panel headphone jack and push buttons.

## Views of the Computer

Figure 1-1 shows the front of the Macintosh LC 575 computer. The figure shows the microphone, the display screen, the locations of the drives, the open/close button for the CD-ROM tray, the front panel headphone jack, the speakers, the power on light, and the push buttons that control the screen intensity and sound level.

**Figure 1-1** Front view of the Macintosh LC 575 computer

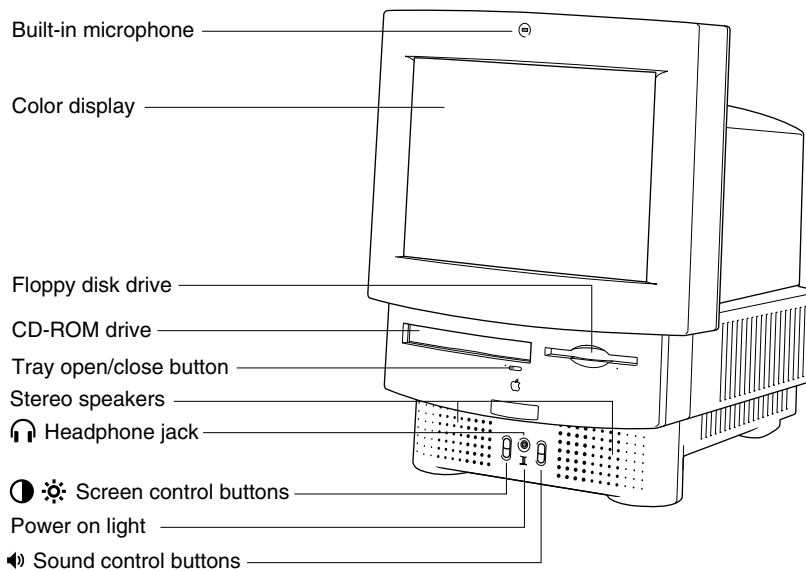

Unlike the CD-ROM drives in some earlier Macintosh models, which used a disc caddy, the CD-ROM drive used in the Macintosh LC 575 uses a sliding tray to hold the disc. See the appendix, “AppleCD 300i Plus,” for more information about the CD-ROM drive.

Figure 1-2 shows the back of the Macintosh LC 575 computer. As the figure shows, the master power switch is located just below the fan grille and the external connectors are located in a row across the lower part of the back cover.

## Access to the Logic Board

Just above the row of I/O connectors on the back of the computer are two projecting tabs. By pushing down on the tabs, the user can remove the connector cover and gain access to the main logic board. The logic board plugs into connectors at the front so that the user can remove it from the case by pulling it out the back. Once the board has been removed, the user can add expansion RAM or plug in an expansion card, as described in later sections of this note.

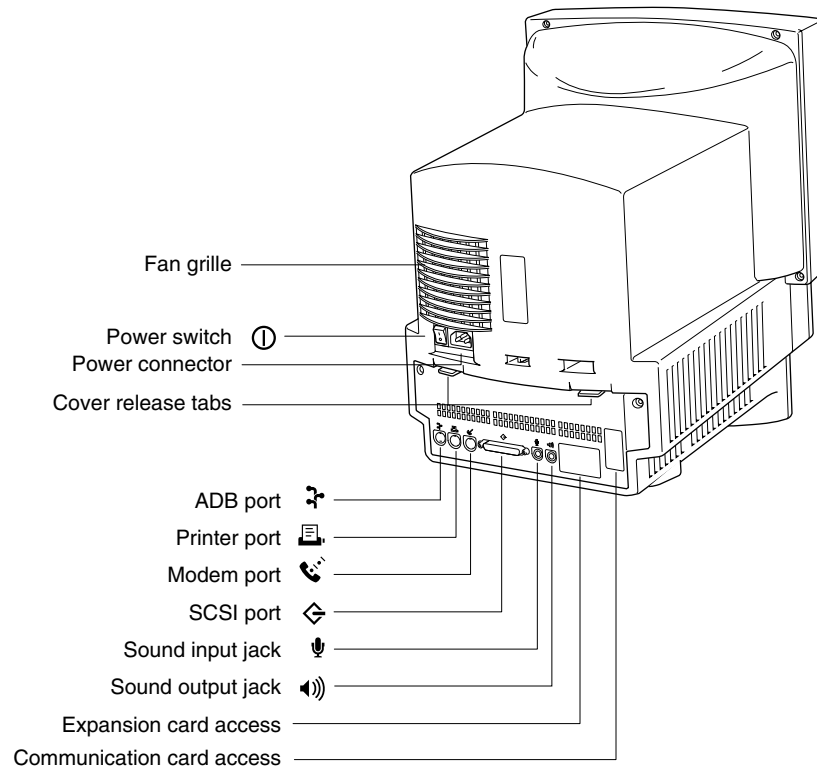
**Figure 1-2** Back view of the Macintosh LC 575 computer

## Built-in Color Display

The Macintosh LC 575 computer has a built-in color display with a 14-inch Trinitron monitor. Like the video interface in the Macintosh LC 520, the video interface in the Macintosh LC 575 computer uses separate VRAM for the screen buffer. The computer does not have an external video connector.

The display screen in the Macintosh LC 575 computer displays the same amount of information as the Macintosh 14-inch color display: 640 by 480 pixels.

### Note

By using the Monitors control panel, the user can select a 16-color, 560-by-384-pixel display mode when the Apple IIe Card for the Macintosh LC is installed in the expansion slot. ♦

## Front Panel Push Buttons

---

The Macintosh LC 575 computer has two pairs of push buttons on the front panel. The pair on the left controls the intensity of the screen; the pair on the right controls the sound level.

### Screen Control Push Buttons

---

The push buttons on the left control the intensity of the screen: pressing the top button causes the intensity to increase, and pressing the bottom button causes the intensity to decrease. If the user holds down a button, the intensity continues to increase (or decrease) until it reaches a maximum (or minimum).

**Note**

The user can also control the screen brightness and contrast by means of the Screen control panel, described in the section “Sound Control Panel” on page 37. ♦

### Sound Control Push Buttons

---

The push buttons on the right control the sound level: pressing the top button causes the level to increase, and pressing the bottom button causes the level to decrease. If the computer is playing a sound when you press one of the sound control push buttons, the sound level changes as long as you continue to press the button. If no sound is playing when you press a sound control push button, the computer plays an alert sound to confirm the new level setting.

**Note**

The computer allows the user to select sound features and control sound levels by means of the Sound control panel, described in the section “Sound Control Panel” on page 37. ♦

## Power On and Off

---

The master power switch on the back of the Macintosh LC 575 must be in the on position for the computer to operate. As long as the master power switch is in the on position, the user can turn the power off and on by pressing the Power key on the keyboard.

**Note**

If you plan to leave the Macintosh LC 575 computer turned off for an extended period of time, you should flip the master power switch to the off position. ♦

If the user attempts to turn off the Macintosh LC 575 computer—using either the Power key or the Shut Down menu item—while files are still open, the system displays an alert box warning the user that files are open and should be closed to avoid loss of data. If the user turns off the master power switch while the computer is operating, the computer shuts off immediately, without performing the safe shutdown.

## Power Saver

The Power Saver is an optional feature that automatically turns off the display whenever the Macintosh LC 575 computer is turned on but is not used for more than a set period of time. The user selects the Power Saver and sets the length of time before the screen turns off by adjusting the slider in the Screen control panel, shown in Figure 1-3. After the Power Saver has turned the display off, the software turns the display back on again whenever the user moves the mouse or presses a key on the keyboard.

### Note

It may take up to several seconds for the screen display to reappear. To let the user know that it has responded to the user's action, the computer emits a series of beeps while this is happening. ♦

**Figure 1-3** Screen control panel

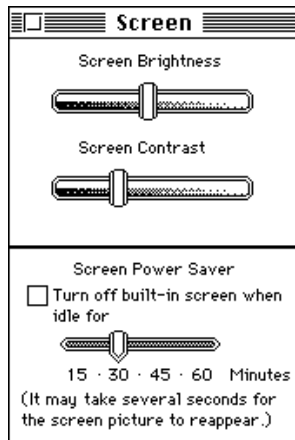

## RAM Expansion

The Macintosh LC 575 computer comes with 4 MB of RAM and 512 KB of VRAM installed. The user can expand the RAM up to a maximum of 36 MB and the VRAM to 1 MB. (Some configurations will have 1 MB of VRAM installed.)

Figure 1-4 shows the possible configurations of RAM. The first 4 MB segment (light gray) is permanently installed; expansion RAM (dark gray) can be added to obtain the total amounts shown in the figure. For more information, see the section “RAM Addresses” on page 30.

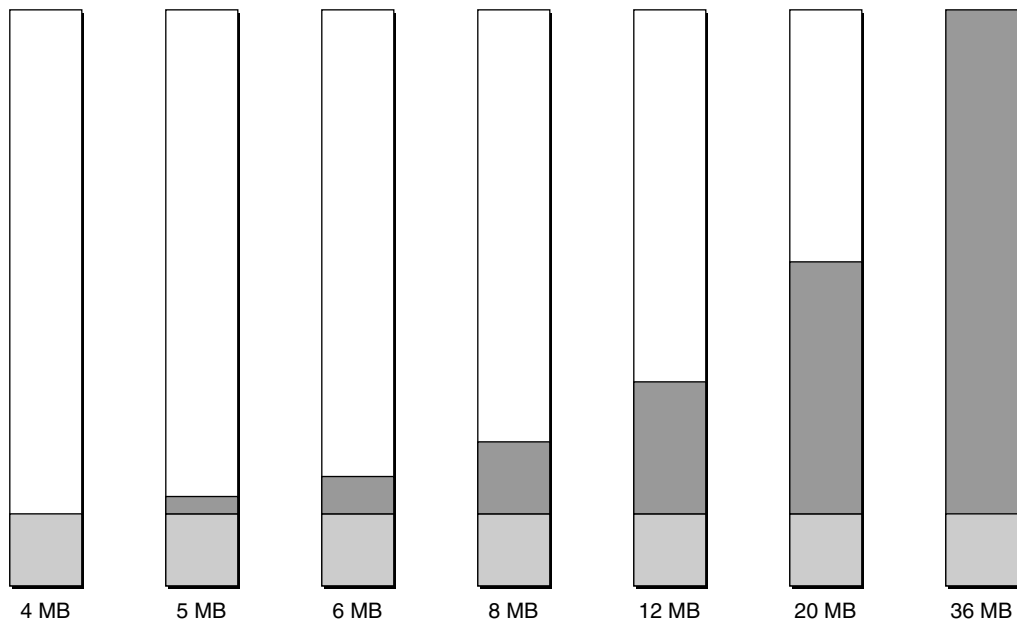
**Figure 1-4** RAM configurations

## RAM SIMMs

The Macintosh LC 575 computer has one RAM expansion socket for a 72-pin RAM SIMM. The access time of the RAM devices must be 80 ns or less.

A SIMM can be either single sided or double sided. Single-sided SIMMs using 1-Mbit, 4-Mbit, or 16-Mbit devices provide RAM expansion of 1 MB, 4 MB, or 16 MB, respectively. Double-sided SIMMs using the same devices provide 2 MB, 8 MB, or 32 MB of RAM expansion.

The RAM SIMM for the Macintosh LC 575 computer is mechanically the same as the 72-pin RAM SIMM used in the Macintosh LC III and the Macintosh LC 475 computers. The mechanical design of the RAM SIMM is based on the industry standard design defined in the JEDEC Standard Number 21-C. Figure 1-5 shows the mechanical specifications and Table 1-2, beginning on page 10, gives the signal assignments. Pin contacts must be tin, not gold or copper, and the circuit board must dedicate one layer to power and one to ground.

### IMPORTANT

RAM SIMMs used in Macintosh computers must meet the timing and electrical standards of those machines. SIMMs designed for other computers may not work. ▲

Figure 1-5 RAM expansion SIMM

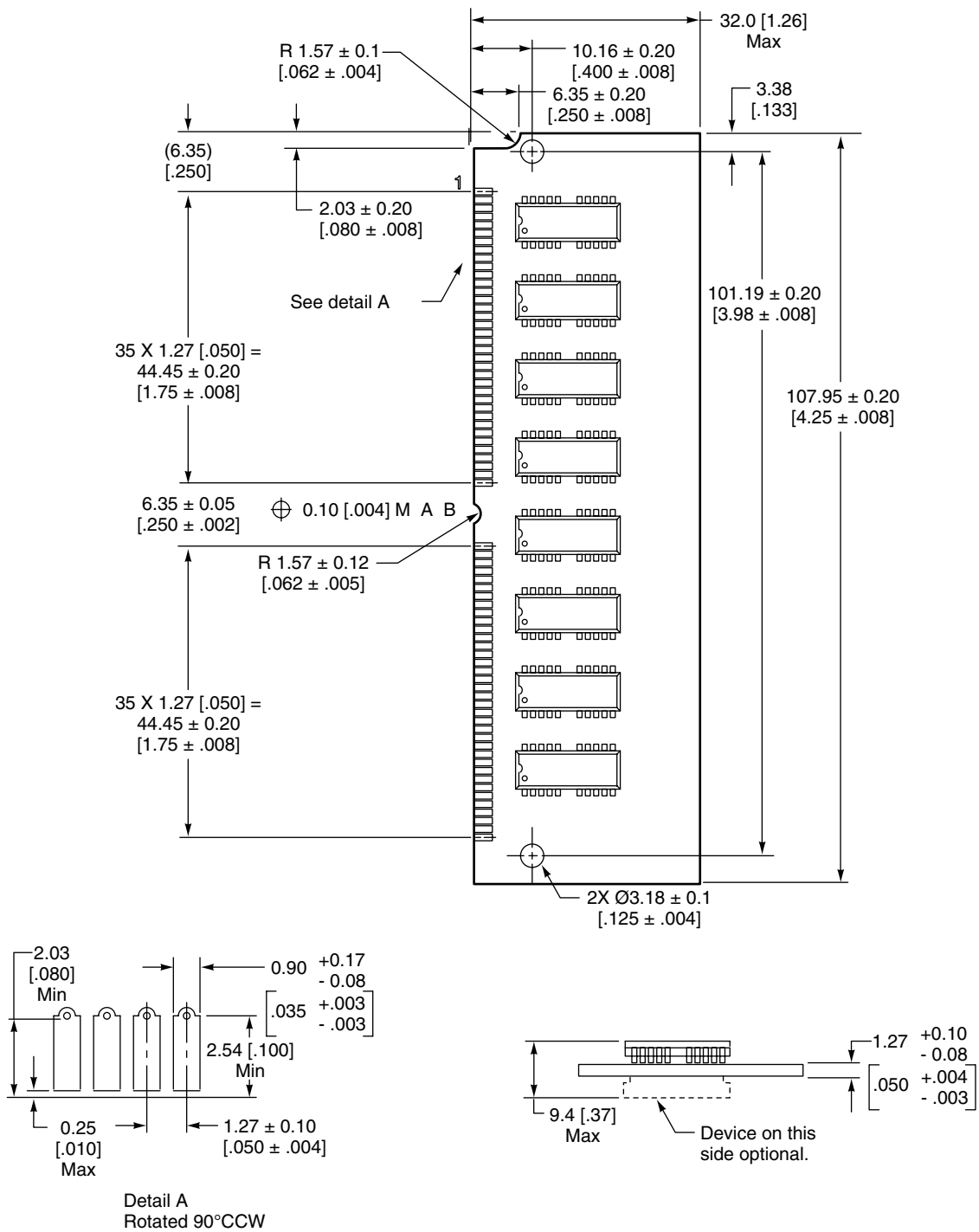

Note: Dimensions are in millimeters with inches in brackets.

**Table 1-2** Signal assignments on the RAM SIMM socket

Pin	Signal name	Description
1	GND	Ground
2	DQ0	Data input/output bus, bit 0
3	DQ16	Data input/output bus, bit 16
4	DQ1	Data input/output bus, bit 1
5	DQ17	Data input/output bus, bit 17
6	DQ2	Data input/output bus, bit 2
7	DQ18	Data input/output bus, bit 18
8	DQ3	Data input/output bus, bit 3
9	DQ19	Data input/output bus, bit 19
10	+5V	+5 volts
11	n.c.	Not connected
12	A0	Address bus, bit 0
13	A1	Address bus, bit 1
14	A2	Address bus, bit 2
15	A3	Address bus, bit 3
16	A4	Address bus, bit 4
17	A5	Address bus, bit 5
18	A6	Address bus, bit 6
19	A10	Address bus, bit 10
20	DQ4	Data input/output bus, bit 4
21	DQ20	Data input/output bus, bit 20
22	DQ5	Data input/output bus, bit 5
23	DQ21	Data input/output bus, bit 21
24	DQ6	Data input/output bus, bit 6
25	DQ22	Data input/output bus, bit 22
26	DQ7	Data input/output bus, bit 7
27	DQ23	Data input/output bus, bit 23
28	A7	Address bus, bit 7
29	A11	Address bus, bit 11
30	+5V	+5 volts
31	A8	Address bus, bit 8

*continued*



**Table 1-2** Signal assignments on the RAM SIMM socket (continued)

Pin	Signal name	Description
32	A9	Address bus, bit 9
33	/RAS3	Row address strobe 3
34	/RAS2	Row address strobe 2
35	—	Reserved
36	—	Reserved
37	—	Reserved
38	—	Reserved
39	GND	Ground
40	/CAS0	Column address strobe 0
41	/CAS2	Column address strobe 2
42	/CAS3	Column address strobe 3
43	/CAS1	Column address strobe 1
44	/RAS0	Row address strobe 0
45	/RAS1	Row address strobe 1
46	n.c.	Not connected
47	/W	Write enable
48	n.c.	Not connected
49	DQ8	Data input/output bus, bit 8
50	DQ24	Data input/output bus, bit 24
51	DQ9	Data input/output bus, bit 9
52	DQ25	Data input/output bus, bit 25
53	DQ10	Data input/output bus, bit 10
54	DQ26	Data input/output bus, bit 26
55	DQ11	Data input/output bus, bit 11
56	DQ27	Data input/output bus, bit 27
57	DQ12	Data input/output bus, bit 12
58	DQ28	Data input/output bus, bit 28
59	+5V	+5 volts
60	DQ29	Data input/output bus, bit 29
61	DQ13	Data input/output bus, bit 13
62	DQ30	Data input/output bus, bit 30

*continued*

**Table 1-2** Signal assignments on the RAM SIMM socket (continued)

Pin	Signal name	Description
63	DQ14	Data input/output bus, bit 14
64	DQ31	Data input/output bus, bit 31
65	DQ15	Data input/output bus, bit 15
66	n.c.	Not connected
67	—	Reserved
68	—	Reserved
69	—	Reserved
70	—	Reserved
71	n.c.	Not connected
72	GND	Ground

## Video RAM

The Macintosh LC 575 computer has two sockets for 68-pin VRAM SIMMs. The pair of SIMMs can contain a total of either 512 KB or 1 MB of VRAM. All the VRAM in the computer is in the SIMMs; there is no VRAM soldered to the logic board. The VRAM SIMMs are the same type as those used in the Macintosh LC 520 and Macintosh LC 475 models.

### IMPORTANT

Both VRAM SIMM sockets must be occupied, and both SIMMs must be the same size, either 256 KB or 512 KB each. ▲

### Note

The computer will not recognize more than 1 MB of VRAM. ◆

The maximum pixel depth available depends on the amount of VRAM installed. With the minimum 512 KB of VRAM installed, the computer can store up to 8 bits per pixel; the screen displays up to 256 colors, software-selectable from a range of 16 million. With 1 MB of VRAM installed, the computer can store up to 16 bits per pixel and display up to 32,768 colors.

### Note

If 1 MB of VRAM has been installed, the user can set the display to 16 bits per pixel by opening the Monitors control panel and choosing Thousands. ◆

## Introduction

Table 1-3 lists the bits per pixel and number of colors available for the different amounts of VRAM.

**Table 1-3** Amount of VRAM and pixel depths supported

Total VRAM	Bits per pixel	Number of colors
512 KB	1, 2, 4, or 8	up to 256
1 MB	1, 2, 4, 8, or 16	up to 32,768

**Note**

When the Apple IIe Card for the Macintosh LC is installed in the expansion slot, the internal display provides a 560-by-384-pixel, 16-color display for running Apple IIe software. For more information, see “Video Display Parameters” on page 30. ♦

## SCSI Bus

---

The Macintosh LC 575 computer has a SCSI bus for the internal hard drive and one or more external SCSI devices. The SCSI bus also supports the optional internal CD-ROM drive.

### SCSI Connectors

---

The internal SCSI connector is a 50-pin connector with the standard SCSI pin assignments. The external SCSI connector is a 25-pin D-type connector with the same pin assignments as other Apple SCSI devices. Table 1-4 on page 14 shows the pin assignments on the internal and external SCSI connectors.

**IMPORTANT**

The internal hard disk and optional CD-ROM drive connect to the SCSI bus by means of connector adapters that allow the drives to slide into their respective mounting bays. For more information about the internal drives and connector adapters, see “Storage Device Slide-In Bays” beginning on page 56. ▲

**Table 1-4** Pin assignments for the internal and external SCSI connectors

Pin number (internal 50-pin)	Pin number (external 25-pin)	Signal name	Signal description
2	8	/DB0	Bit 0 of SCSI data bus
4	21	/DB1	Bit 1 of SCSI data bus
6	22	/DB2	Bit 2 of SCSI data bus
8	10	/DB3	Bit 3 of SCSI data bus
10	23	/DB4	Bit 4 of SCSI data bus
12	11	/DB5	Bit 5 of SCSI data bus
14	12	/DB6	Bit 6 of SCSI data bus
16	13	/DB7	Bit 7 of SCSI data bus
18	20	/DBP	Parity bit of SCSI data bus
25	–	n.c.	Not connected
26	25	TPWR	+5 V terminator power
32	17	/ATN	Attention
36	6	/BSY	Bus busy
38	5	/ACK	Handshake acknowledge
40	4	/RST	Bus reset
42	2	/MSG	Message phase
44	19	/SEL	Select
46	15	/C/D	Control or data
48	1	/REQ	Handshake request
50	3	/I/O	Input or output
20, 22, 24, 28, 30, 34, and all odd pins except pin 25	7, 9, 14, 16, 18, and 24	GND	Ground

## SCSI Bus Termination

The internal portion of the SCSI bus must be long enough to connect both the internal hard disk and the optional internal CD-ROM drive, so the bus requires termination at both ends. As in other Macintosh models, the external end of the bus is normally terminated at the last external device. In the Macintosh LC 575 computer, the internal end of the bus—the end at the internal hard disk drive—is terminated in the drive itself.

## Introduction

The Macintosh LC 575 computer includes special circuitry that automatically provides the proper termination when no external device is connected, that is, when the SCSI bus ends at the external connector. When no external device is connected, the circuitry connects the bus to a terminator on the logic board near the external connector. When one or more external SCSI devices are connected, the circuitry detects the external termination during system reset and disconnects the termination on the logic board.

## Comparison of SCSI Arrangements

---

There are now three arrangements of SCSI cabling and termination used in Macintosh computers.

The first arrangement is used on Macintosh computers that support only one internal SCSI device (examples include the Macintosh LC II and the Macintosh Quadra 700). Terminators built into the internal SCSI device terminate the internal end of the SCSI bus. A separate terminator block at the last external device terminates the external end of the SCSI bus.

The second arrangement is used on the Macintosh Quadra 900 and 950 computers. Those machines have two SCSI driver ICs, one for the internal SCSI devices and one for the external devices. (The software treats the two hardware buses as one virtual bus with a single set of SCSI ID numbers.) The internal and external SCSI cables are both terminated on the logic board. In addition, the internal cable is so long that it—like the external cable—requires termination at both ends, so it has built-in SCSI terminators for the last device. While this arrangement provides for higher transmission speeds because the two segments of the bus are terminated separately, it is expensive because it has two driver ICs and two sets of active terminators on the logic board.

The third arrangement is used in the Macintosh LC 575 computer as well as other recently introduced models with more than one internal SCSI device, such as the Macintosh LC 520 and the Macintosh Quadra 610 and 650. As described in the previous section, that arrangement uses a single SCSI driver IC for both internal and external devices and provides automatic termination on the logic board.

## Floppy Disk Drive

---

The Macintosh LC 575 computer has one internal high-density floppy disk drive (Apple SuperDrive). The drive is connected to the logic board by a 20-pin connector. Table 1-5 on page 16 shows the pin assignments for the floppy disk connector.

**IMPORTANT**

The floppy disk drive uses a special connector adapter so that it can be installed by sliding it into a bay in the computer's chassis. See "Storage Device Slide-In Bays" beginning on page 56 for information about connector adapters. ▲

**Table 1-5** Pin assignments for the internal floppy disk connector

Pin number	Signal name	Signal description
1	GND	Ground
2	PH0	Phase 0: state control line
3	GND	Ground
4	PH1	Phase 1: state control line
5	GND	Ground
6	PH2	Phase 2: state control line
7	GND	Ground
8	PH3	Phase 3: register write strobe
9	n.c.	Not connected
10	/WRREQ	Write data request
11	+5V	+5 volts
12	SEL	Head select
13	+12V	+12 volts
14	/ENBL	Drive enable
15	+12V	+12 volts
16	RD	Read data
17	+12V	+12 volts
18	WR	Write data
19	+12V	+12 volts
20	n.c.	Not connected

## Serial I/O Ports

The Macintosh LC 575 computer has two serial ports, one for a printer and one for a modem. Both serial I/O ports use standard 8-pin mini-DIN sockets. Table 1-6 shows the signal assignments on the serial ports.

Both serial ports include the GPi (general-purpose input) signal on pin 7. The GPi signal for each port connects to the corresponding data carrier detect input on the SCC (Serial Communications Controller). On serial port A (the modem port), the GPi line can be connected to the receive/transmit clock (RTxCA) signal on the SCC. That connection supports devices that provide separate transmit and receive data clocks, such as synchronous modems. For more information about the serial ports, see *Guide to the Macintosh Family Hardware*, second edition.

**Table 1-6** Serial port signals

Pin number	Signal name	Signal description
1	HSKo	Handshake output
2	HSKi	Handshake input
3	TxD-	Transmit data -
4	SG	Ground
5	RxD-	Receive data -
6	TxD+	Transmit data +
7	GPi	General-purpose input
8	RxD+	Receive data +

## Communications Options

The Macintosh LC 575 computer comes with an internal communications interface installed in a socket on the main logic board. The communications interface can be one of three options: a 14.4 megabaud modem, an Ethernet interface with an AUI connector, or an Ethernet interface with a 10baseT connector.

### IMPORTANT

The socket for the communications interface in the Macintosh LC 575 computer is not an expansion connector. ▲

## ADB Ports

The Apple Desktop Bus (ADB) port on the Macintosh LC 575 is functionally the same as on other Macintosh computers.

The ADB is a single-master, multiple-slave serial communications bus that uses an asynchronous protocol and connects keyboards, graphics tablets, mouse devices, and other devices to the Macintosh LC 575 computer. The custom ADB microcontroller drives the bus and reads status from the selected external device. A 4-pin mini-DIN connector connects the ADB controller to the outside world. Table 1-7 on page 18 lists the ADB connector pin assignments. For more information about the ADB, see *Guide to the Macintosh Family Hardware*, second edition.

### Note

The total current available for all devices connected to the +5V pin on the ADB is 500 mA. Each device should use no more than 100 mA. ◆

**Table 1-7** ADB connector pin assignments

Pin number	Signal name	Signal description
1	ADB	Bidirectional data bus used for input and output; an open-collector signal pulled up to +5 volts through a 470-ohm resistor on the main logic board.
2	PSW	Power on signal; generates reset and interrupt key combinations.
3	+5V	+5 volts from the computer.
4	GND	Ground from the computer.

## Sound

Like other Macintosh computers, the Macintosh LC 575 computer can create sounds digitally and play the sounds through its internal speakers or send the sound signals out through the sound out connector and the headphone jack. This section describes the sound inputs and outputs; for information about the internal sound circuitry, see “PrimeTime IC” on page 26 and “DFAC II IC” on page 27.

### Sound Inputs

The Macintosh LC 575 has both a built-in microphone and an external sound input jack.

#### Built-in Microphone

The microphone is located on the front of the computer, above the screen, and is connected internally to the main logic board.

The user selects the built-in microphone as the sound source by using the Sound control panel, as described in the section “Sound Control Panel” on page 37.

#### Sound Input Jack

The Macintosh LC 575 computer has a sound input jack on the back for connecting an external microphone or other sound source. The sound input jack accepts a standard 1/8-inch phone plug, either monophonic or stereophonic (two signals plus ground).

The sound input jack accepts either the Apple PlainTalk line-level microphone or a pair of line-level signals by way of a separate adapter. The internal circuitry mixes the stereophonic signals into a monophonic signal.

#### Note

The Apple PlainTalk microphone requires power from the main computer, which it obtains by way of an extra-long, 4-conductor plug that makes contact with a 5-volt pin inside the sound input jack. ♦



**IMPORTANT**

The microphone for the Macintosh LC and LC II computers does not work with the Macintosh LC 575 computer, which requires the line-level signal provided by the Apple PlainTalk microphone. ▲

## Sound Outputs

---

The Macintosh LC 575 has a pair of built-in stereo speakers as well as an external sound output jack on the back and a headphone jack on the front.

### Built-in Speakers

---

The Macintosh LC 575 has two built-in loudspeakers at the bottom of the front panel. Each speaker has its own audio amplifier; the internal sound circuitry supports stereo sound output.

**Note**

Inserting a plug into either the sound output jack on the back or the headphone jack on the front disconnects the internal speakers. ◆

### Sound Output Jacks

---

The Macintosh LC 575 has two sound output jacks, one on the back and another on the front. The sound output jacks are connected in parallel.

The amplifier for the sound output jacks provides a nominal 0.5-volt signal at an impedance of 39 ohms. The sound output signal is suitable for driving either a line-level input or stereo headphones. If both output jacks are used at the same time and the combined impedance falls below 39 ohms, the signal may suffer from clipping.

## Sound Modes

---

The sound mode is selected by means of a call to the Sound Manager. The sound circuitry normally operates in one of four modes:

- Sound playback: computer-generated sound is sent to the speaker and the sound output jack.
- Sound playback with playthrough: computer sound and sound input are mixed and sent to the output.
- Sound record: sound input is recorded; this is the preferred method for recording, especially when using the built-in microphone.
- Sound record with playthrough: input sound is recorded and also fed through to the output.

One way of using sound record with playthrough is in the recording of sounds from a CD or CD-ROM.

## Introduction

**Note**

To prevent feedback that might be audible, an application should not select playthrough mode when either microphone has been selected as the sound input source. For more information, see the section “Sound Control Panel” on page 37. ♦

## Sample Rates

---

The Macintosh LC 575 computer can record and play back sound at either of two sample rates: 11,000 samples per second or 22,000 samples per second. The sound circuits include input and output filters with switchable cutoff frequencies that correspond to the two sampling rates: a 3.5-kHz cutoff for the 11,000 sample rate and a 7-kHz cutoff for the 22,000 sample rate.

## Keyboard

---

The Macintosh LC 575 computer comes with a separate keyboard like the one used with the Macintosh LC 520. The keyboard has a Power key, identified by the symbol ⌘. The user can turn the power on and off from the keyboard.

**Note**

There are no programmer’s switches on the Macintosh LC 575 computer, so the user invokes the reset and NMI functions by pressing Command-key combinations while holding down the Power key, as shown in Table 1-8. The Command key is identified by the symbols ⌘ and ⌘. The user must hold down a key combination for at least 1 second to allow the ADB microcontroller enough time to respond to the NMI or hard-reset signal. ♦

**Table 1-8** Reset and NMI key combinations

---

Key or key combination	Function
Power (⌘)	Power on and off
Command-Power (⌘-⌘)	NMI (always active)
Control-Command-Power (Control-⌘-⌘)	Reset

**Note**

The NMI in the Macintosh LC 575 computer can always be activated from the keyboard. This is a change from the Macintosh LC computer, in which the keyboard NMI function can be deactivated by the software. ♦

## Expansion Slot

---

The Macintosh LC 575 computer has a single internal expansion slot. The expansion slot is the same as the one in the Macintosh LC 475 and the Macintosh Quadra 605. The slot can accept either a 96-pin expansion card designed for the Macintosh LC II or a 114-pin expansion card designed for the Macintosh LC III and Macintosh LC 520. Chapter 4, “Expansion,” describes the signals on the expansion slot and gives guidelines for designing an expansion card for the Macintosh LC 575 computer.

**IMPORTANT**

The expansion slot is not a PDS because it does not connect directly to the computer’s MC68LC040 microprocessor. The expansion slot supports cards designed to work with the MC68030 microprocessor; see Chapter 4, “Expansion,” for details. ▲



# Architecture

---

## Architecture

This chapter describes the architecture of the Macintosh LC 575 computer. The chapter describes the main components on the logic board and explains the features that are different from those of earlier Macintosh computers.

## Block Diagram and ICs

---

The architecture of the Macintosh LC 575 computer is based on the architecture of the Macintosh Centris 610 and 650 computers. It uses the same microprocessor and custom ICs as those earlier machines, as shown in the block diagram in Figure 2-1.

**Note**

The Macintosh Quadra 610 and 650 are more recent versions of the Macintosh Centris 610 and 650 with higher processor clock speeds. ♦

The computer architecture has two internal buses. The system bus is connected directly to the MC68LC040 and runs at the same clock rate. The I/O bus is partially buffered from the MC68LC040 and runs at 16 MHz. The PrimeTime custom IC, described later, buffers the data portion of the I/O bus and provides a compatible interface for I/O devices and software designed for use with the MC68030.

### Microprocessor

---

The Macintosh LC 575 computer uses the Motorola MC68LC040 microprocessor with a 25-MHz system clock.

The MC68LC040 microprocessor is a low-cost version of the MC68040 without the built-in FPU. The MC68LC040 has all the other features of the MC68040; the performance of the MC68LC040 is the same as that of the MC68040 except for floating-point operations.

**Note**

The MC68LC040 is different in many ways from the MC68020 and MC68030. For example, the built-in MMU in the MC68LC040 is not the same as the MC68851 MMU or the built-in MMU in the MC68030. Also, the caches in the MC68LC040 use a new mode called CopyBack mode. For information about these differences and the way they are reflected in the new ROM software developed for the MC68040, see Chapter 4, “Software.” For more information about cache operation in Macintosh computers, see the Technical Note number HW06 *Cache as Cache Can*. ♦

In the Macintosh LC 575 computer, the MC68LC040 microprocessor is installed in a socket. That makes it possible to upgrade to an MC68040 by removing the MC68LC040 from its socket and replacing it with an MC68040.

Figure 2-1 Block diagram of the Macintosh LC 575 computer

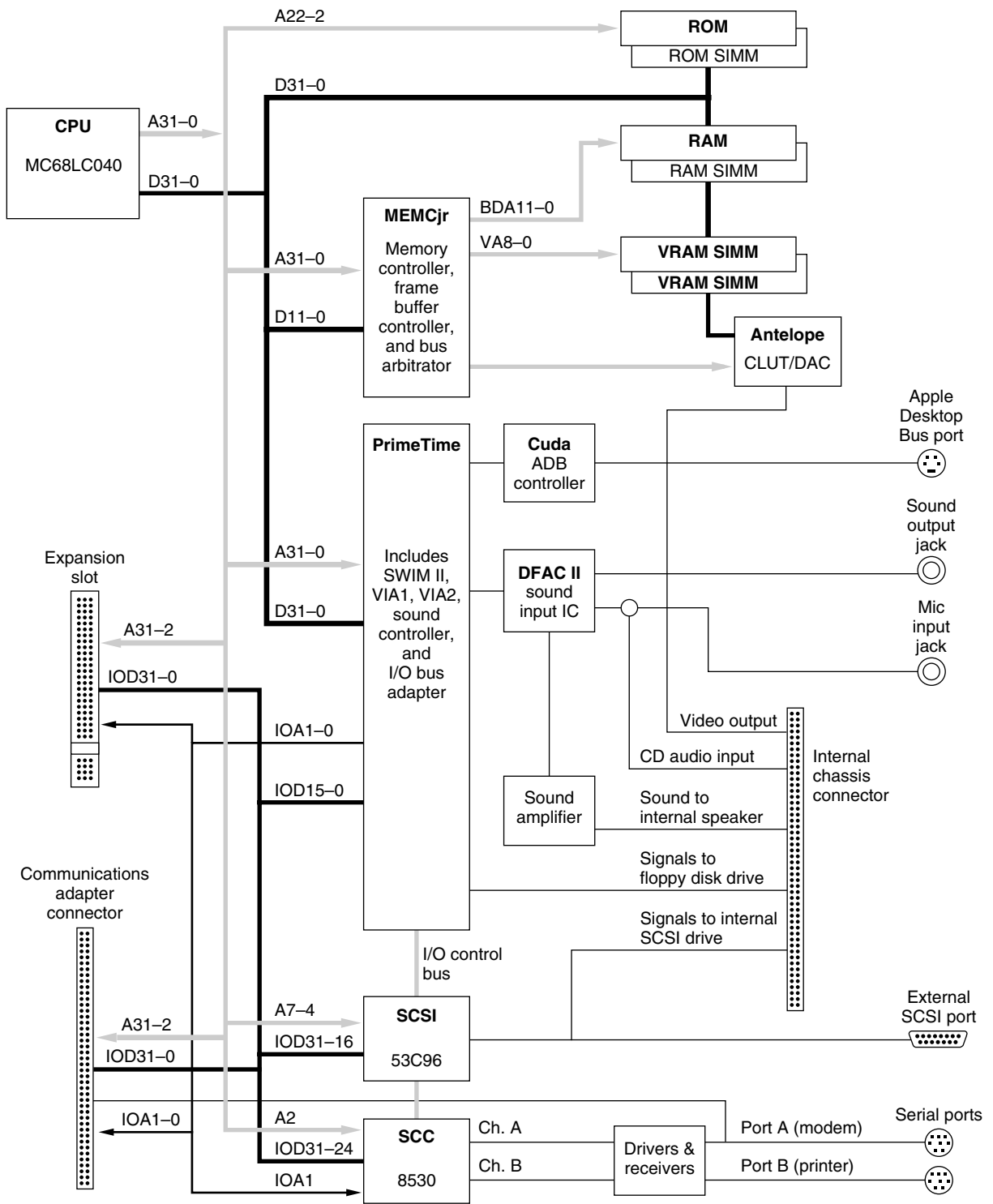

## Architecture

**IMPORTANT**

An expansion board can not provide an FPU coprocessor because the MC68LC040 microprocessor does not support the coprocessor interface and the signals on the expansion connector are not connected directly to the CPU. ▲

## Custom ICs

---

The Macintosh LC 575 computer uses five custom VLSI integrated circuits:

- the MEMCjr memory controller
- the PrimeTime I/O subsystem and buffer
- the DFAC II sound input processor
- the Cuda ADB controller
- the Antelope video CLUT and DAC

The computer also uses several standard ICs that are used in other Macintosh computers, including the 8530 SCC serial I/O controller and the 53C96 SCSI controller. This section describes only the custom ICs.

### MEMCjr IC

---

The MEMCjr IC combines functions performed by several ICs in previous Macintosh designs. The MEMCjr includes

- control and timing signals for the ROM, RAM, and VRAM
- control logic for system bus arbitration
- a frame buffer controller for the video display

The MEMCjr IC is similar to the MEMC IC used in the Macintosh Centris 610 and 650.

**Note**

The frame buffer controller in the MEMC and MEMCjr ICs is compatible with the DAFB IC used in the Macintosh Quadra 700, 900, and 950 computers. ◆

### PrimeTime IC

---

The PrimeTime IC combines functions performed by several ICs in previous Macintosh designs. The PrimeTime IC includes

- data bus buffers for the internal I/O bus
- a SWIM II floppy disk controller
- interface adapters VIA1 and VIA2



## Architecture

- address decoding for I/O devices
- sound control logic and buffers

The PrimeTime IC provides the data bus features of the MC68030 that the MC68040 does not provide. Those features are *byte steering*, which allows 8-bit and 16-bit devices to be connected to a fixed byte lane, and *dynamic bus sizing*, which allows software to read and write longwords to 8-bit and 16-bit devices. Those features allow the computer to work with existing I/O software designed for the MC68030.

The PrimeTime IC also contains the sound control logic and the sound input and output buffers. There are three separate buffers—one for sound input and two for stereo sound output—so the computer can record sound input and process sound output simultaneously.

## DFAC II IC

---

The DFAC II custom IC contains the sound input processing devices. The DFAC II includes

- input AGC comparators
- input antialias filtering
- A/D converter for input
- PWM converter for output

The DFAC II IC does not include the sound control logic and the input and output buffers; those are part of the PrimeTime IC.

For sound input, the DFAC II processes the signal from the sound input jack or the built-in microphone through a sound input amplifier with AGC, an input antialiasing filter, an A/D converter, and the necessary switching circuits. The DFAC II sends the resulting stream of digital sound data to the PrimeTime IC, which stores the data in its input buffer.

For sound output, circuits in the DFAC II take data from the sound output buffers and generate stereo pulse-width-modulated (PWM) signals. The DFAC II merges the sound playthrough signal with the PWM signals and sends the combined signals to an external stereo PWM converter IC. After low-pass filtering in the PWM converter, the signals go to the sound output jacks and to a separate amplifier for each built-in speaker.

### Note

Inserting a plug into either the sound output jack on the back or the headphone jack on the front disconnects the internal speakers. ♦

Architecture

## Cuda IC

---

The Cuda IC is a custom version of the Motorola MC68HC05 microcontroller. It includes

- the ADB interface
- the programming interface for the DFAC II IC
- parameter RAM
- the real-time clock
- power control using the Power key

For information about the functions of the Power key, see the section “Power On and Off” on page 6.

## Antelope IC

---

The Antelope IC is a custom IC containing the video CLUT (color look-up table) and DAC. The Antelope IC is pin and software compatible with the AC/DC custom IC used in the Macintosh Quadra 700 and 950, but does not support 24 bits per pixel or Apple convolution. For information about the number of bits per pixel provided on different video monitors, see “Video RAM Addresses” in the next section.

A separate pixel data bus handles data transfers from the VRAM to the Antelope IC. The pixel data bus is 32 bits wide and all data transfers take place 32 bits at a time. The Antelope IC breaks each 32-bit data transfer into several pixels of the appropriate size—1, 2, 4, 8, or 16 bits per pixel. The Antelope IC does not support 24 bits per pixel.

The CLUT in the Antelope custom IC provides color palettes for 4-bit and 8-bit display modes. In 16-bit display mode, the CLUT is used to provide gamma correction for the stored color values. With a black-and-white or monochrome display mode, all three color components (R, G, and B) are the same.

## Address Maps

---

The Macintosh LC 575 computer supports both 24-bit and 32-bit addressing. Figure 2-2 shows the relationship between the 24-bit addresses and the 32-bit addresses. The address map is similar to that of the Macintosh Quadra 610 and 650 computers.

### Note

Developers should not use actual hardware addresses in applications but should always communicate with hardware devices by means of system software. ♦

**Figure 2-2** Simplified 24-bit and 32-bit address maps

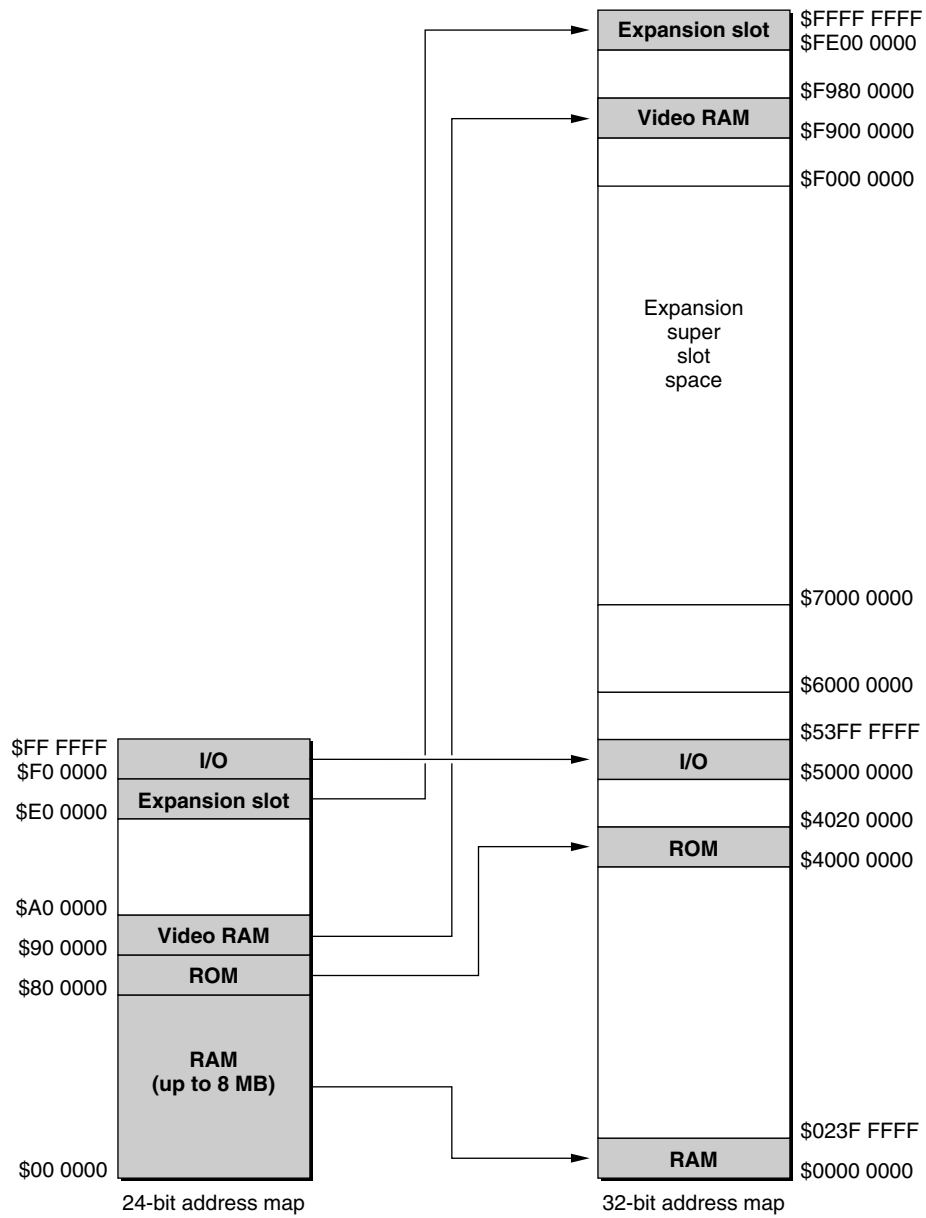

## RAM Addresses

---

The first 1 GB of the address space is reserved for RAM. The actual amount of RAM installed can be from 4 MB to 36 MB. At startup time, a routine in the ROM determines the amount of RAM available and stores the size in a low-memory global variable.

## Video RAM Addresses

---

The Macintosh LC 575 computer uses separate VRAM to store the screen buffer. The VRAM occupies dedicated address space starting at \$F900 0000, as shown in Figure 2-2.

## Expansion Card Addresses

---

The expansion card should use address space from \$FE00 0000 to \$FEFF FFFF, corresponding to NuBus™ slot \$E, or from \$E000 0000 to \$EFFF FFFF, corresponding to NuBus super slot \$E. For more information, see the section “Address Space” on page 52.

# Video Display Parameters

---

The built-in video display on the Macintosh LC 575 computer has the same number of pixels as the display used with the AppleColor High-Resolution RGB Monitor: 640 by 480 pixels. The resolution is 69 dpi.

Table 2-1 lists the video timing parameters for the built-in display. Figure 2-3 on page 32 shows simplified timing diagrams and identifies the horizontal and vertical timing parameters in a video signal.

**Note**

When the Apple IIe Card for the Macintosh LC is installed in the expansion slot, the computer generates an Apple IIe video display with 560 by 384 pixels. The Apple IIe display uses the standard video timing but displays only a 560-by-384-pixel area in the middle of the display. ♦

## Architecture

**Table 2-1** Video timing parameters

<b>Parameter</b>	<b>Standard value</b>
Dot clock	30.24 MHz
Dot time	33.07 ns
Line rate	35.00 kHz
Line time	28.57 $\mu$ s (864 dots)
Horizontal active video	640 dots
Horizontal blanking	224 dots
Horizontal front porch	64 dots
Horizontal sync pulse	64 dots
Horizontal back porch	96 dots
Frame rate	66.67 Hz
Frame time	15.00 ms (525 lines)
Vertical active video	480 lines
Vertical blanking	45 lines
Vertical front porch	3 lines
Vertical sync pulse	3 lines
Vertical back porch	39 lines

Figure 2-3 Video timing diagram

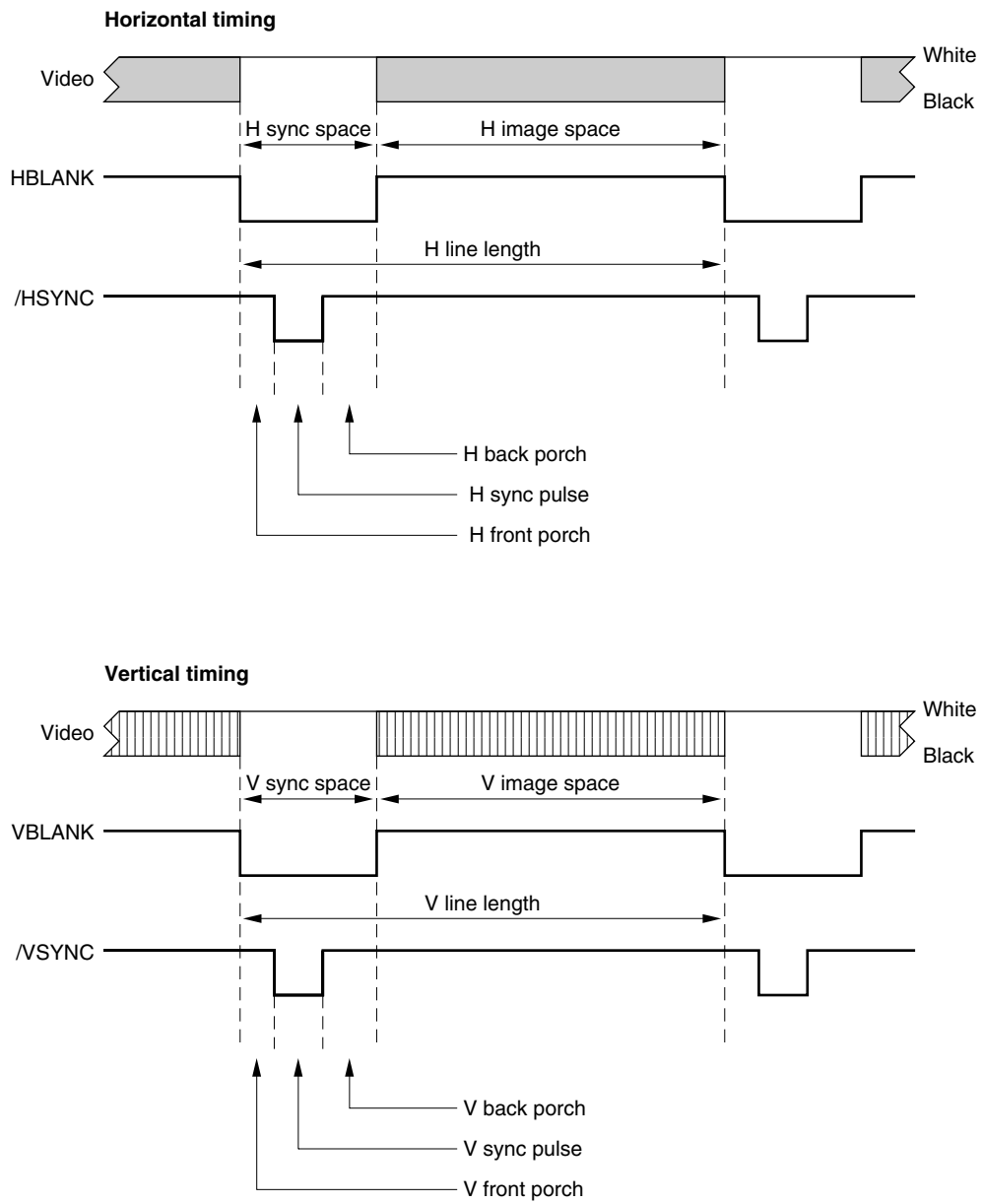

# Software

---

## Software

The first part of this chapter describes the software in the ROM of the Macintosh LC 575 computer. The second and third parts describe the system software and the Screen driver that support its new features.

## ROM Software

---

The ROM in the Macintosh LC 575 computer is based on the ROM for the Macintosh Quadra 610 and 650 models with the necessary changes to support machine-specific hardware.

The sections that follow describe the following changes in the ROM:

- modularity
- machine identification
- new memory controller
- new memory maps
- new video ICs
- new sound IC and sound primitives
- ADB and power management
- push button interrupts
- Power Saver software

### Modularity

---

The ROM has been designed to detect optional features and configure the software appropriately. The optional features include

- an Ethernet interface
- an internal modem
- an FPU (on an MC68040 in the main processor socket)

### Machine Identification

---

The ROM includes new tables and code for identifying the machine.

Applications can find out which computer they are running on by using the Gestalt Manager routines; see *Inside Macintosh: Overview*. The `gestaltMachineType` value is 92 (hexadecimal \$5C).



## New Memory Controller

---

The ROM code has been modified to support the MEMCjr custom IC, which has different features and a different programming interface from the MEMC IC. Unlike the MEMC, the MEMCjr supports 1 MB and 2 MB SIMMs, as well as the larger sizes listed on page 8.

## New Memory Maps

---

The ROM code has been modified to support the memory addressing used by the Macintosh LC 575 computer. ROM code determines the size of RAM and sets up the MMU to make the RAM addresses contiguous. The ROM includes descriptions of the memory space needed for setting up the MMU.

The ROM code also creates the physical-space tables the computer needs in order to run virtual memory. To be able to run with virtual memory active, the computer uses the 32-bit Memory Manager and runs in 32-bit mode.

The ROM adds an MMU table that provides access to the video frame buffer in 24-bit address space so that the Apple IIe card will work on these machines.

## New Video ICs

---

The video frame buffer controller in the MEMCjr custom IC is similar to the DAFB IC used in the Macintosh Quadra models. The video driver code has been changed to accommodate the differences between the MEMCjr IC and the previous MEMC IC and to support a new video clock generator IC.

## New Sound IC and Primitives

---

The sound primitives (low-level routines) for the Macintosh LC 575 computer are the same as those in the Macintosh LC 520 computer. The primitives have been integrated into the main ROM code. Vector tables provide offsets to the primitives for different machines.

The ROM includes changes to handle the DFAC II sound IC and to support the sound control push buttons.

## ADB and Power Management

---

The Cuda IC provides the ADB interface, parameter RAM, and power management. The ROM code to support the Cuda IC was originally developed for the Macintosh LC 520 computer.

The ROM provides the soft power off capability, shutting down the computer when the user selects Shut Down in the Finder's Special menu.

Software

## Push Button Interrupts

---

The ROM includes routines for initializing the push button interrupt bits in the interrupt enable and flag registers and for initializing other new registers that support the push buttons.

Pushing any of the four push buttons on the front of the case causes the computer to set a bit in a new register, the push button register, which in turn causes a level-2 interrupt. The interrupt handler disables the push button interrupt until the button that caused the interrupt is released.

## Power Saver Software

---

The ROM software includes code that implements the Power Saver mode, which turns off the power to the display after a set interval of time. Applications can turn the monitor on and off and read its status by making the appropriate call to the Screen driver (`.BCScreen`). For more information, see the section “Screen Driver” beginning on page 40.

### Note

The screen can remain dark for several seconds after the screen is reactivated, so the system emits a series of beeps to reassure the user that the computer is still operating. The Screen driver call that turns the monitor back on also causes a call to the Notification Manager to play the `SysBeep` sounds. When the screen is being reactivated, the keyboard and mouse are disabled until the screen reappears. ♦

## System Software

---

The Macintosh LC 575 computer requires System 7.1 or a later version of system software. The disk labeled “Install Me First” includes a system enabler file that contains the resources the system needs to start up and initialize the computer.

The system disk includes an Installer application to install the control panels for the new features of the machine.

The system software includes the following new features:

- a system enabler for these machines
- a bootable CD-ROM
- enhanced QuickDraw
- new control panels
- Screen driver software

The Screen driver is described in its own section later in this chapter.

---

## System Enabler

---

Starting with the international release of System 7.1, each reference release of the Macintosh system software supports a new startup extension, the system enabler. A *system enabler* is a software resource that is able to perform the correct startup process for one or more Macintosh computers.

As soon as the system software on disk takes over the startup process, it searches for all system enablers that can start up the particular machine. Each system enabler contains a resource that specifies which computers it is able to start up and the time and date of its creation. If the system software finds more than one enabler for the particular computer, it passes control to the one with the most recent time and date.

In general, the system enabler included in each reference release of system software is able to start up all previous computers. The system enabler that accompanies a later computer will be able to start up that computer, possibly using resources from the previous reference release.

---

## Booting From a CD-ROM

---

The Macintosh LC 575 computer can start up (boot) from a built-in CD-ROM drive. Starting up in this fashion is not recommended, because the system software was not designed to operate from a locked storage device—one that the software can't write to. The system software that Apple Computer uses on the system CD-ROM includes only one control panel file—for setting the startup disk—along with Installer software to install the system onto a hard disk. Developers may wish to use a similar arrangement to distribute bulky software.

---

## Enhanced QuickDraw

---

Like other Macintosh models that use the MC68040 microprocessor, the Macintosh LC 575 computer has code in the system enabler to modify some QuickDraw drawing routines. The code provides new QuickDraw routines that take advantage of the MOVE16 instruction in the MC68040 to speed up vertical scrolling and solid fills.

---

## New Control Panels

---

The system software on the Macintosh LC 575 computer includes new control panels for the sound level and the screen brightness and contrast.

---

### Sound Control Panel

---

The Sound control panel has a pop-up menu that allows the user to switch between the Alert Sounds panel and the Sound In panel.

## Software

With the Alert Sounds panel, the user can adjust the sound level either with the slider in the control panel or with the push buttons on the front of the case. The panel changes the slider to reflect changes in the sound level caused by the user pressing one of the sound push buttons. Figure 3-3 shows the Sound control panel with Alert Sounds selected.

**Figure 3-1** Sound control panel showing alert sounds

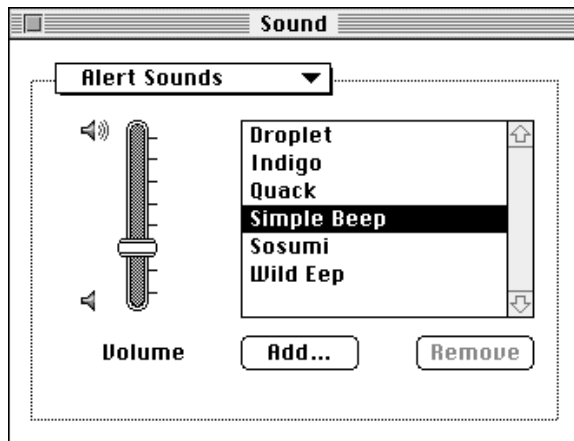

When the user clicks the Add button, the computer displays a dialog box for recording a new sound up to 10 seconds long, as shown in Figure 3-3.

**Figure 3-2** Dialog box for adding a sound

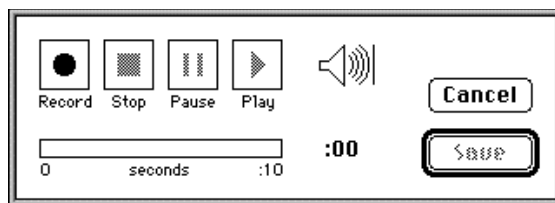

The Sound In control panel allows the user to select the source of sound input, which can be either the built-in microphone or a device plugged into the sound input jack. Figure 3-3 shows the Sound control panel with Sound In selected.

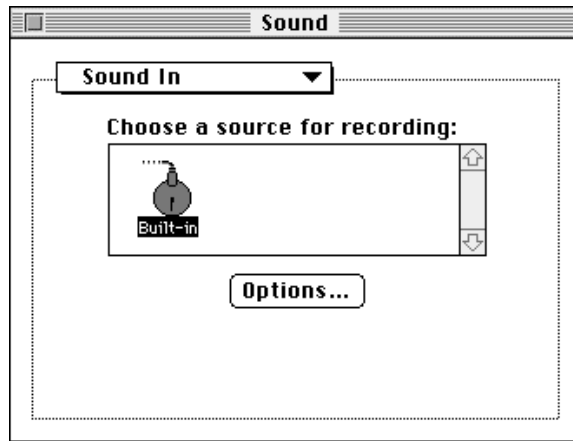
**Figure 3-3** Sound control panel showing sound in I

When the user clicks the Options button, a dialog box appears, as shown in Figure 3-4. The user can then select either the internal microphone, an external microphone, the line-level inputs, or the internal CD audio.

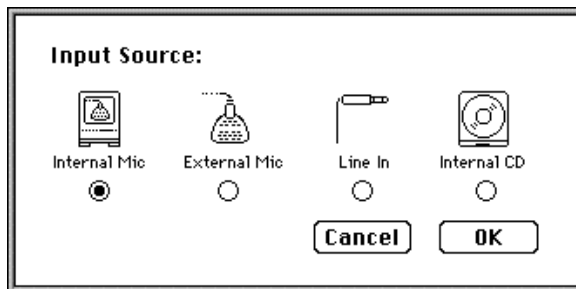
**Figure 3-4** Sound input options

Either the external microphone or line-level inputs can be plugged into the sound input jack. When the user selects the corresponding input device in the options dialog box, the computer sets the gain appropriately.

Software

## Screen Control Panel

---

The Macintosh LC 575 computer has a Screen control panel with two sliders for adjusting the brightness and contrast and one to set the idle time for the Power Saver. The user can adjust a slider by dragging with the mouse and can adjust the brightness and contrast using the arrow keys or the number keys. Figure 3-5 shows the Screen control panel.

**Figure 3-5** Screen control panel

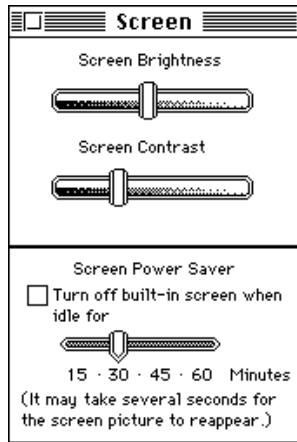

### Note

The Screen control panel uses minimum and maximum values supplied by the Screen driver to avoid setting the screen so dark or so light that the user cannot see the control panel to make further adjustments. ♦

## Screen Driver

---

Applications can read and set the brightness and contrast of the screen by making appropriate status and control calls to the Screen driver (`.BCScreen`). The system startup code uses the Screen driver to set the initial screen values.

### Note

The Screen driver is machine specific; it does not support all Macintosh models. ♦

The current values of brightness and contrast are stored as byte values in parameter RAM. If the startup software finds a value below the minimum startup value, it sets it to a default minimum value.

## Screen Driver Calls

---

Calls to the screen driver use the `ParamBlockRec` method as described in the Device Manager chapter of *Inside Macintosh: Devices*. The parameter passing conventions are the standard ones: the calling program passes a pointer to the parameter block in register A0.

Because the Screen driver is opened at startup and is never closed, and because there is nothing to read or write, the following calls are not supported:

- `CloseDriver`
- `FSRead`
- `FSWrite`
- `KillIO`

The following calls are supported by the Screen driver:

- `PBOpen`
- `PBControl`
- `PBStatus`

## PBOpen

---

```
PBOpen (paramBlock: ParmBlkPtr; async: Boolean) : OSErr_Open
```

### Parameter block

→	<code>ioCompletion</code>	<code>nil</code>
←	<code>ioResult</code>	<code>noErr (0)</code>
→	<code>ioNamePtr</code>	Pointer to the name <code>BCScreen</code>
←	<code>ioRefNum</code>	Driver's reference number
→	<code>ioPermsn</code>	Must be <code>fsCurPerm</code>

When the system software opens the Screen driver at startup time, the Device Manager creates a device control entry (DCE) and stores its handle in the proper unit table entry. Subsequent `PBOpen` calls merely return `refNum` and a result (`noErr`). Programs can use the `PBOpen` call to obtain the `refNum` value for use in control and status calls.

High-level call:

```
OpenDriver (name: Str255; VAR refNum: Integer) : OSErr
```

## PBControl

---

```
PBControl (paramBlock: ParmBlkPtr; async: Boolean) : OSErr_Control
```

**Parameter block**

```
→ ioCompletion  nil
← ioResult      controlErr (-17) if csCode is unimplemented;
                 otherwise noErr (0)
→ ioRefNum      Driver's reference number
→ csCode        Identifies the call; described below
→ csParam       Depends on the call; described with the csCode values
                 where it is used (csParam is an array of 11 shorts)
```

csCode values:

Name	Value	Description
CtrlScrnBright	\$4301	Set screen brightness PWM value between 0 and 255 in csParam[0]
CtrlSaveBright	\$4302	Store current brightness to PRAM
CtrlScrnCont	\$4307	Set screen contrast PWM value between 0 and 255 in csParam[0]
CtrlSaveCont	\$4308	Store current contrast to PRAM
CtrlScreenOff	\$4309	Turn off power to internal monitor
CtrlScreenOn	\$4310	Turn on power to internal monitor

Programs can use the `PBControl` call to set the screen brightness and contrast, store the current setting into PRAM, and turn power to the internal monitor on and off.

High-level call:

```
Control (refNum: Integer; csCode: Integer; csParamPtr: Ptr) : OSErr
```

## PBStatus

---

```
PBStatus (paramBlock: ParmBlkPtr; async: Boolean) : OSErr_Status
```

**Parameter block**

```
→ ioCompletion  nil
← ioResult      controlErr (-17) if csCode is unimplemented;
                 otherwise, noErr (0)
→ ioRefNum      Driver's reference number
→ csCode        Identifies the call; described below
→ csParam       Depends on the call; described with the csCode values
                 where it is used (csParam is an array of 11 shorts)
```



## Software

csCode values:

<b>Name</b>	<b>Value</b>	<b>Description</b>
StatScrnBright	\$5301	Return current screen brightness in csParam[0] (value = 0-255)
StatBrtMinMax	\$5303	Return minimum and maximum brightness values: csParam[0] = maximum brightness, csParam[1] = minimum brightness
StatScrnCont	\$5307	Return current screen contrast in csParam[0] (value = 0-255)
StatConMinMax	\$5308	Return minimum and maximum contrast values: csParam[0] = maximum contrast, csParam[1] = minimum contrast
StatScrnOnOff	\$5309	Return on/off state of internal monitor in csParam[0]: \$00FF = monitor power is on, \$0000 = monitor power is off

Programs can use the `PBStatus` call to read the current settings of the screen brightness and contrast, read the brightness and contrast values stored in PRAM, and read the state of the power to the internal monitor.

High-level call:

```
Status (refNum: Integer; csCode: Integer; csParamPtr: Ptr) : OSErr
```



# Expansion

---

## Expansion

The Macintosh LC 575 computer has a slot for an I/O expansion card. This chapter describes the expansion slot and gives the specifications for an expansion card.

**IMPORTANT**

The expansion slot in the Macintosh LC 575 computer is not a PDS because it is not connected directly to the main processor. PDS cards designed to interact with the main processor—to provide, for example, a RAM cache or an FPU—will not work in the expansion slot in the Macintosh LC 575. ▲

## Expansion Slot

---

The expansion slot in the Macintosh LC 575 computer is the same as the one in the Macintosh LC 475 and the Macintosh Quadra 605. The slot can accept either of two types of expansion cards: a 96-pin card similar to the PDS card used in the Macintosh LC II or a 114-pin card similar to the PDS card used in the Macintosh LC III and the Macintosh LC 520.

The expansion connector in the Macintosh LC 575 computer is mechanically the same as the expansion connector in the Macintosh LC III and the Macintosh LC 520. It is essentially a 120-pin Euro-DIN connector with six pins removed to make a notch. The notch divides the connector into two sections: a 96-pin section that accepts the 96-pin connector used on expansion cards for the Macintosh LC II, and a separate 18-pin section for additional signals. For more information, see the section “Card Connectors” on page 52.

### Pin Assignments

---

Table 4-1 gives the pin assignments for the expansion connector. Pins 1 through 32 in all three rows (A, B, and C) correspond to the 96-pin section of the connector. Pins 33 and 34 in all three rows are missing—those pins correspond to the notch in the connector. Pins 35 through 40 in all three rows make up the 18-pin section of the connector.

Except for one signal, 16MASTER (on pin B31 and described in Table 4-2), the pin assignments on the 96-pin section of the extended PDS are the same as those on the PDS in the Macintosh LC II. On the Macintosh LC II, pin B31 is the Apple II video clock input.

**Note**

Signal names starting with a slash (/) are active when their signal lines are driven to a logical zero (0). ◆

**IMPORTANT**

Under no circumstances should you use the analog GND pin (pin 1, row B) as a digital ground on your expansion card. Doing so will cause digital noise to be coupled into the audio system, resulting in degraded sound quality. ▲

## Expansion

**Table 4-1** Pin assignments for the expansion connector

Pin number	Row A	Row B	Row C
1	SNDOUT	Analog GND	/FPU.SEL
2	/SLOTIRQ	/R/W	/DS
3	/PDS.AS	+5V	/BERR
4	/PDS.DSACK1	+5V	/PDS.DSACK0
5	/HALT	SIZ1	SIZ0
6	FC2	GND	FC1
7	FC0	CLK16M	/RESET
8	/RMC	GND	/SLOT.BG
9	D31	D30	D29
10	D28	D27	D26
11	D25	D24	D23
12	D22	D21	D20
13	D19	D18	D17
14	D16	D15	D14
15	D13	D12	D11
16	D10	D9	D8
17	/BGACK	/BR	A0
18	A1	A31	A27
19	A26	A25	A24
20	A23	A22	A21
21	A20	/IPL2	/IPL1
22	/IPL0	D3	D4
23	D2	D5	D6
24	D1	D0	D7
25	A4	A2	A3
26	A6	A12	A5
27	A11	A13	A7
28	A9	A8	A10
29	A16	A15	A14
30	A18	A17	A19

*continued*

## Expansion

**Table 4-1** Pin assignments for the expansion connector (continued)

Pin number	Row A	Row B	Row C
31	/FANSPEED	16MASTER	FC3
32	+12V	GND	-5V
33	(not present)	(not present)	(not present)
34	(not present)	(not present)	(not present)
35	A28	/CPU.BG	C16M
36	A29	+5V	A30
37	/CIOUT	/CPU.AS	/STERM
38	/CBACK	n.c.	/CBREQ
39	n.c.	/CPU.DSACK0	n.c.
40	n.c.	GND	/CPU.DSACK1

All the signals on the expansion connector are capable of driving at least one TTL load (1.6 mA sink, 400  $\mu$ A source). Most of the signals are connected to other MOS devices on the main logic board; for those signals, the DC load on the bus signals is small. All the data lines (D0–D31) are connected to the PrimeTime custom IC so they have CMOS-type loads.

▲ **WARNING**

The SNDOUT pin (row A, pin 1) must not be grounded; doing so will short-circuit the +5V power to the sound circuitry. If you don't use the SNDOUT pin, leave it unconnected. ▲

## Signal Descriptions

The expansion slot in the Macintosh LC 575 computer is intended to be compatible with expansion cards designed for computers that use the MC68030 microprocessor (the Macintosh LC III and Macintosh LC 520 computers). Because the bus protocols of the MC68LC040 microprocessor are not the same as those of the MC68030, many of the signals on the expansion slot are not connected directly to the MC68LC040. Instead, those signals are connected to the PrimeTime custom IC, which emulates the MC68030 control and data buses.

The upper 30 address lines (A31–2) are connected directly to the MC68LC040 microprocessor. The I/O bus adapter logic in the PrimeTime IC provides the buffered data bus (D31–0) and the two lowest address lines (A1–0).

Table 4-2 describes the signals on the expansion connector.

**Table 4-2** Expansion connector signal descriptions

<b>Signal name</b>	<b>Signal description</b>
A0–A31	Address lines.
/BERR	Bus error; bidirectional signal indicating that an error occurred during the current bus cycle; when /HALT is also asserted, causes the bus cycle to be retried.
/BGACK	Bus grant acknowledge; input signal indicating that external device has become bus master.
/BR	Bus request; input signal indicating that external device is requesting to become bus master.
/CBACK	CPU burst acknowledge; used with /STERM during a burst transfer to indicate that an individual element of a burst transfer is ready.
/CBREQ	CPU burst request; used to initiate a quadruple longword burst transfer; tied to a 4.7K pull-up resistor.
/CIOUT	Cache inhibit out signal from main processor, indicating that a second-level cache is allowed to participate in the current bus transaction; tied to a 300 $\Omega$ pull-down resistor.
CLK16M	Independent clock running at 15.6672 MHz; provided for compatibility with Macintosh LC and LC II PDS cards.
/CPU.AS	Address strobe; three-state signal indicating that an active bus transaction is occurring.
/CPU.BG	Processor bus grant; signal from the external device can become bus master following completion of current processor bus cycle. This signal is electrically connected to the /SLOT.BG signal.
/CPU.DSACK0, /CPU.DSACK1	Data strobe acknowledge signals; asserted by the addressed bus slave to end a bus transaction; also used to inform the master of the size of the slave's data port. These signals are electrically connected to the corresponding /PDS.DSACK signals.
C16M	Same signal as CLK16M.
D0–D31	Data lines.
/DS	Data strobe. During a read operation, /DS is asserted when the external device should place data on the data bus; during a write operation, /DS is asserted when the main processor has put valid data on the data bus.
/FANSPEED	Increases the speed of the system fan when asserted; all expansion cards should tie this signal to ground (asserted).
FC0–FC2	Function code used to identify address space of current bus cycle; tied to pull-up and pull-down resistors to indicate supervisor data space accesses.
FC3	Additional function code bit, used to indicate that the software is running in 32-bit address mode. (As in the Macintosh LC II, the software always runs in 32-bit mode.)
/FPU.SEL	Select signal for an optional MC68881 or MC68882 FPU; tied to a 4.7K pull-up resistor; never asserted by the logic board.

*continued*

**Table 4-2** Expansion connector signal descriptions (continued)

Signal name	Signal description
/HALT	Used in conjunction with /BERR signal to terminate a bus cycle with a retry response; not used to stop processor execution.
/IPL0-IPL2	Interrupt priority-level lines.
/PDS.AS	Address strobe; synchronized to 16 MHz regardless of the actual processor speed; asserted only when a valid slot address is being generated by the bus master. When the card is the active bus master, the card may drive either this signal or /CPU.AS, but not both.
/PDS.DSACK0, /PDS.DSACK1	Data strobe acknowledge signals; asserted by the addressed bus slave to end a bus transaction; also used to inform the master of the size of the slave's data port. These signals are electrically connected to the corresponding /CPU.DSACK signals.
/RESET	Bidirectional signal that initiates system reset.
/RMC	Three-state output signal that identifies current bus cycle as part of an indivisible bus cycle such as a read-modify-write operation.
/R/W	Read/write; three-state output signal that defines direction of bus transfer with respect to the current bus master; logical one (1) indicates a bus-master read, zero (0) indicates bus-master write.
16MASTER	Indicates the width of the data port when the card is alternate bus master. A logical one (1) indicates a 16-bit port; logical zero (0) indicates a 32-bit port. The signal is pulled high on the main logic board.
SIZ0-SIZ1	Three-state output signals that work in conjunction with PrimeTime IC's dynamic bus sizing capabilities and indicate the number of bytes remaining to be transferred during current bus cycle.
/SLOT.BG	Bus grant signal to the expansion card. A bus master card may take control of the system bus after all pending bus traffic has been completed (when /PDS.AS, /BGACK, and all /DSACK signals are inactive). This signal is electrically connected to the /CPU.BG signal.
/SLOTIRQ	Interrupt request line from the card; reported to the system by way of the slot \$E interrupt request; when low, generates a level-2 interrupt if the slot interrupt enable bit is set.
SNDOUT	Input to the speaker amplifier so that the card can drive the speaker independently of the main processor. This signal accepts only sound output by the method used on the original Apple II, using digital (TTL) levels.
/STERM	Indicates termination of a synchronous transfer by a card using the MC68030 synchronous cycle.



## Expansion

The following signals on the expansion slot are permanently connected:

/PDS.DSACK0	is connected to	/CPU.DSACK0
/PDS.DSACK1	is connected to	/CPU.DSACK1
/SLOT.BG	is connected to	/CPU.BG

Unlike those signals, the /PDS.AS signal is not connected to the /CPU.AS signal. The /PDS.AS signal is used only for addresses in the slot \$E address range; the /CPU.AS signal is used for addresses in expansion slot and super slot spaces \$6–\$8, \$A–\$D, and \$F (the slot \$9 address spaces are used for built-in video circuitry).

**IMPORTANT**

The expansion slot does not support MC68040 bus transfers. The expansion slot does not support a processor operating at a clock frequency other than 16 MHz. ▲

## Compatibility With Older Cards

---

While the expansion slot will accept PDS cards designed for the Macintosh LC II and LC III, some of those cards do not work. Cards that are incompatible with the expansion slot in the Macintosh LC 575 include the following:

- Cards designed to work as coprocessors with an MC68020 or an MC68030 or as replacements for those microprocessors. Such cards include accelerators, 68882 FPU cards, and cache cards. That type of card won't work because the microprocessor is different and because the slot signals are not connected directly to the microprocessor.
- Cards with drivers that include incompatible code. Some drivers that do not obey Apple's programming guidelines don't work on machines that use the MC68040 microprocessor. For example, some of those drivers write directly to the cache control register in an MC68030. Such code won't work on an MC68040.
- Cards with drivers that include code to check the `gestaltMachineType` value and refuse to run on a newer CPU. The idea seems to be to protect the users by refusing to run on a machine that the cards haven't been tested on. This is a general problem and applies to all new Macintosh models.

## Expansion Card

---

The I/O expansion card is approximately 3 inches wide by 5 inches long. It mounts parallel to the main logic board and reaches to an opening in the back of the case (normally filled by a snap-out cover). The opening provides access to a 15-pin D-type connector on the card for external I/O.

## Expansion

## Mechanical Design

---

The I/O expansion card for the Macintosh LC 575 computer is the same size and shape as the PDS card for the Macintosh LC III computer. “Foldouts” at the end of this note contains mechanical drawings showing the recommended design guidelines for the expansion card. Foldout 1 shows the maximum dimensions of the expansion card and the location of the expansion connector. Foldout 2 provides component height restrictions for the expansion card. Foldout 3 shows how the card is installed on the main logic board.

## Card Connectors

---

The custom 114-pin PDS connector on the computer’s main logic board accepts either a 96-pin or 120-pin standard Euro-DIN connector. You can order connectors meeting Apple specifications from Amp Incorporated, Harrisburg, PA 17105, or from Augat Incorporated, Interconnect Products Division, P. O. Box 779, Attleboro, MA 02703. Refer to *Designing Cards and Drivers for the Macintosh Family*, third edition, for more information about those connectors.

## Power for the Card

---

The maximum current available at each supply voltage is shown in Table 4-3. The card must not dissipate more than 4 W total; for example, if the card uses the maximum current at -5 V and +12 V, it must not use more than 300 mA from the +5 V supply.

**Table 4-3** Power available for the expansion card

Voltage	Current
+5	800 mA
-5	20 mA
+12	200 mA

▲ **WARNING**

Cards dissipating more than 4 W may generate excess heat that can damage the computer’s circuitry or cause it to become inoperable. ▲

## Address Space

---

The expansion card’s address space depends on the memory addressing mode. In 24-bit mode, the card appears in address space \$E0 0000-\$EF FFFF; in 32-bit mode, the card appears in physical address spaces \$E000 0000-\$EFFF FFFF and \$FE00 0000-\$FEFF FFFF. To match the conventions used by the Slot Manager, software should address the card as if it were in slot space \$E: either the 16 MB slot space \$FE00 0000-\$FEFF FFFF or the super slot space \$E000 0000-\$EFFF FFFF.

## Expansion

The expansion card must generate its own select signal from the address and function code signals on the connector. The card select signal must be disabled when FC0, FC1, and FC2 are all active; that condition corresponds to a function code of 111 (CPU space). Figure 4-1 shows a typical logic circuit for generating the card select signal.

**Figure 4-1** Generating the card select signal

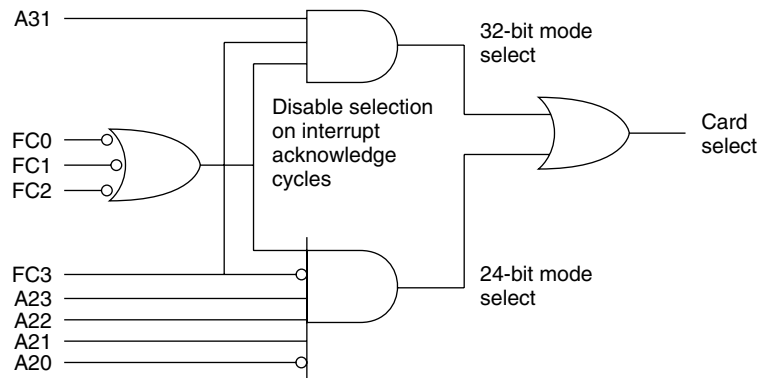
**IMPORTANT**

To ensure compatibility with future hardware and software, you should minimize the chance of address conflicts by decoding all the address bits. To ensure that the Slot Manager recognizes your card, the card's declaration ROM must reside at the upper address limit of the 16 MB address space (\$FE00 0000–\$FEFF FFFF). ▲

## Bus Master on a Card

The expansion slot will support a card with an MC68020 or MC68030 bus master. The PrimeTime custom IC controls bus arbitration between the card's bus master and the MC68LC040 microprocessor so that either bus master will eventually obtain the bus. The MC68020 or MC68030 will obtain the I/O data bus and the address bus. The MC68LC040 will obtain the processor data bus and the address bus. Because there is only one address bus, there can be only one bus master at a time.

Asynchronous transfers are the preferred method for data transfers to and from an expansion card. When an expansion card contains an active bus master, the PrimeTime IC terminates successful data transfers using the DSACK signals. A slave on the expansion card can also terminate a transfer using DSACK signals.

The PrimeTime IC can never be a synchronous slave on the I/O bus, so PrimeTime cannot terminate data transfers as a slave using /STERM. However, a bus slave on an expansion card can terminate a 32-bit-wide synchronous transfer using /STERM. PrimeTime supports /STERM terminations as a master on the I/O bus, and all transfers from PrimeTime to the expansion slot are based on the 16 MHz clock.



# Internal Storage Devices

---

This chapter describes the internal storage devices in the Macintosh LC 575 computer. The computer accommodates one floppy disk drive, one half-height hard disk, and an optional AppleCD 300i CD-ROM drive.

**IMPORTANT**

This chapter describes the internal storage devices in the Macintosh LC 575 computer, but does not include design guides for developers. Because the front drive bezel does not include a separate component for the CD-ROM drive, and because the internal drives are specially modified to permit slide-in mounting, Apple Computer, Inc., does not recommend that developers provide internal storage devices for the Macintosh LC 575 computer. ▲

## Storage Device Slide-In Bays

---

The hard disk drive, floppy disk drive, and optional CD-ROM drive slide into their respective mounting bays in the computer chassis. Connections to each drive are made by one or more connector adapters that fit onto the connector pins on the drive. When you slide a drive into its bay, the connector adapter fits into a matching socket at the back of the bay. Figure 5-1 shows how the AppleCD 300i CD-ROM drive slides into its bay in the front of the computer. The other internal storage devices are installed in much the same way, except that the bay for the hard disk drive is in the back of the computer, behind the removable back cover.

**Note**

To remove the front drive bezel, insert a flat screwdriver into the slot on the bottom of the bezel and twist while sliding the bezel downward. ◆

As Figure 5-1 illustrates, the Macintosh LC 575 computer uses special adapters that allow internal storage devices to slide into place and plug directly into the computer. The connectors on the devices themselves must be located properly so that the connector adapters will fit. Figure 5-2 shows the connector locations on the internal CD-ROM drive. Figure 5-3 on page 58 shows the connector locations on the internal hard disk drive.

The internal hard disk uses a single connector adapter that incorporates both the signal pins and the power pins. The optional CD-ROM drive uses two connector adapters. The first of those is similar to the hard disk adapter and incorporates both signal and power pins. The second adapter is for the separate audio connector.

**Figure 5-1** Installation of the internal CD-ROM drive

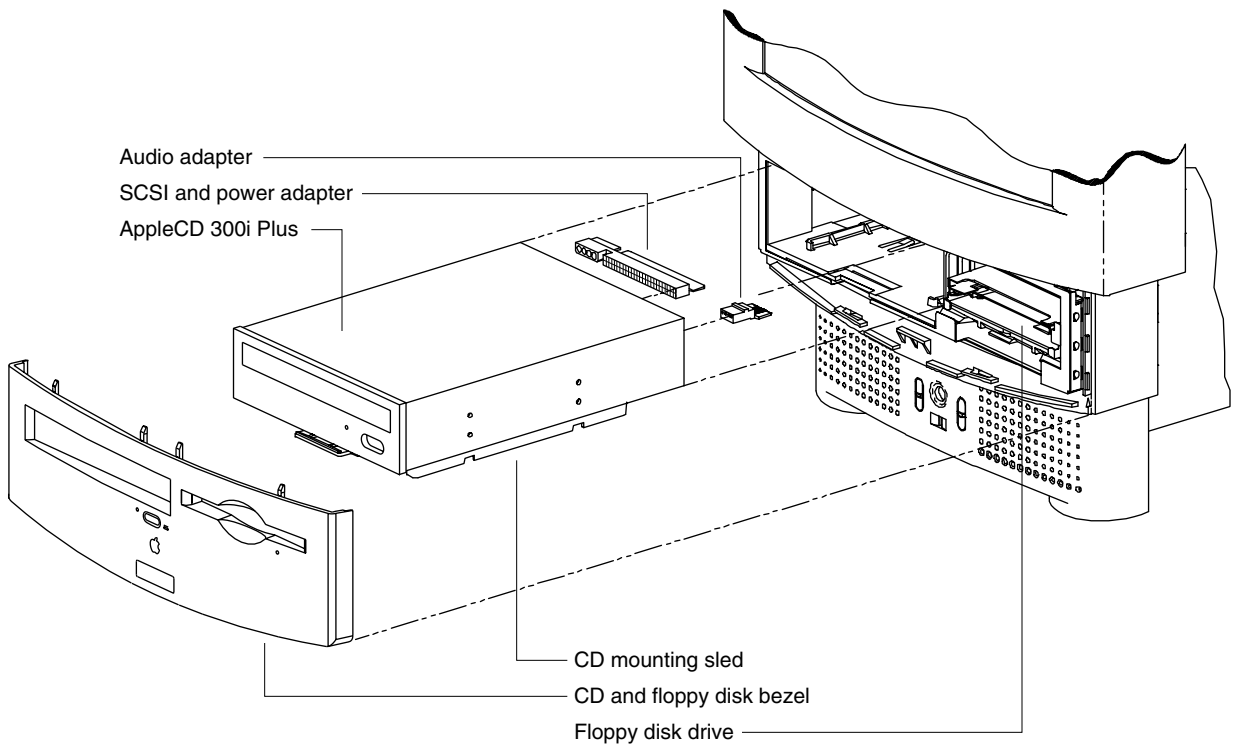

**Figure 5-2** Connector locations on the CD-ROM drive

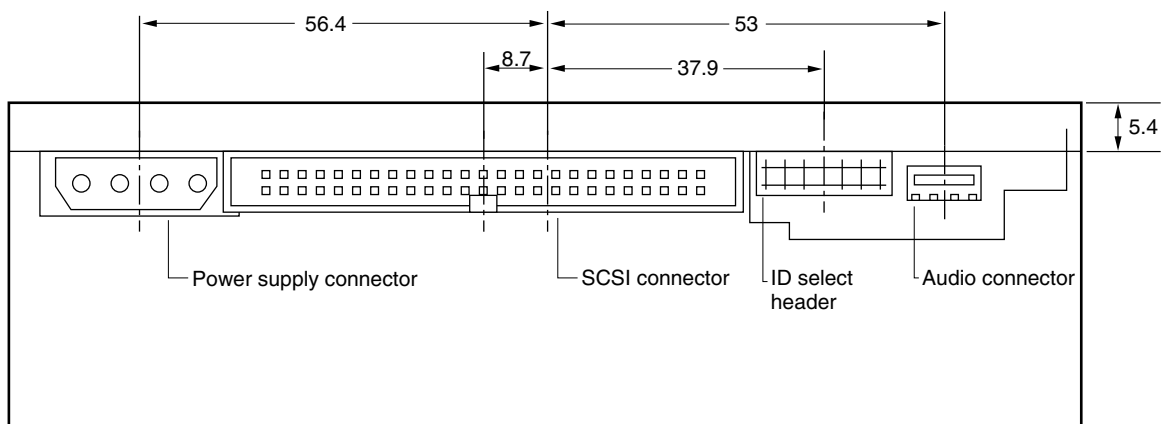

*Note:* Dimensions are in millimeters.

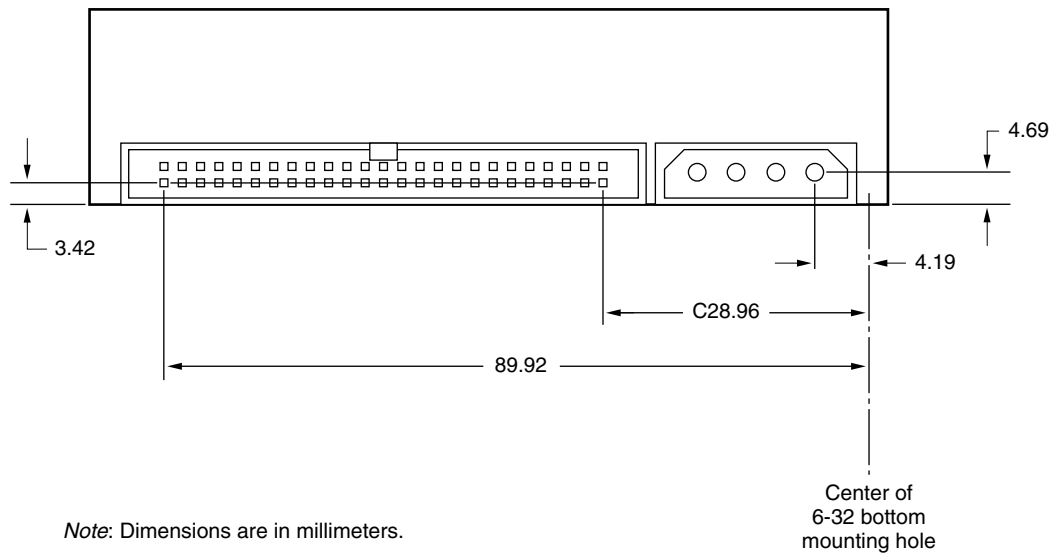
**Figure 5-3** Connector locations on the hard disk drive

## Internal CD-ROM Drive

This section describes the dimensions, mounting method, and power budget for the AppleCD 300i Plus CD-ROM drive installed in the Macintosh LC 575 computer. See the appendix, “AppleCD 300i Plus,” for other information about the CD-ROM drive.

### Note

Unlike the earlier AppleCD 300 models, which used a disc caddy, the AppleCD 300i Plus uses a sliding tray to hold the disc. ♦



## Dimensions of the CD-ROM Drive

Figure 5-1 shows the dimensions of the AppleCD 300i CD-ROM drive.

**Figure 5-4** Dimensions of the CD-ROM drive

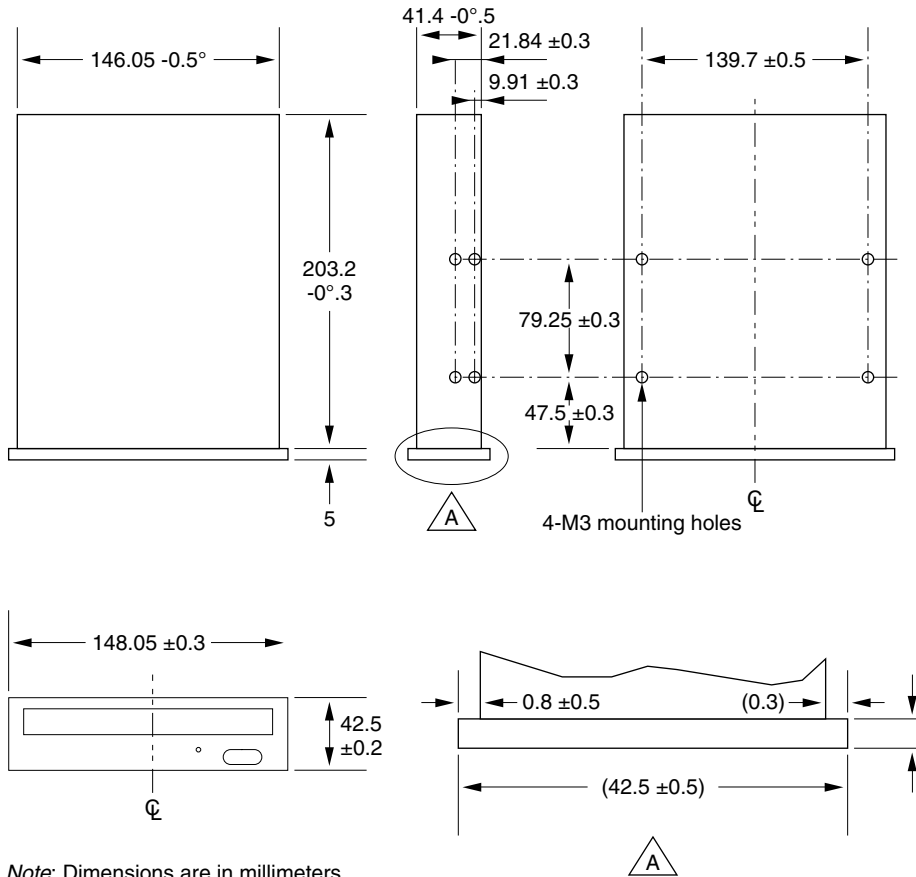

Note: Dimensions are in millimeters.

## Mounting Method for the CD-ROM Drive

Figure 5-5 shows the AppleCD 300i CD-ROM drive mounted on the sled that secures it in the mounting bay. The sled is included in the AppleCD 300i mounting kit for the Macintosh LC 575 computer.

**Figure 5-5** The AppleCD 300i CD-ROM drive mounted on the sled

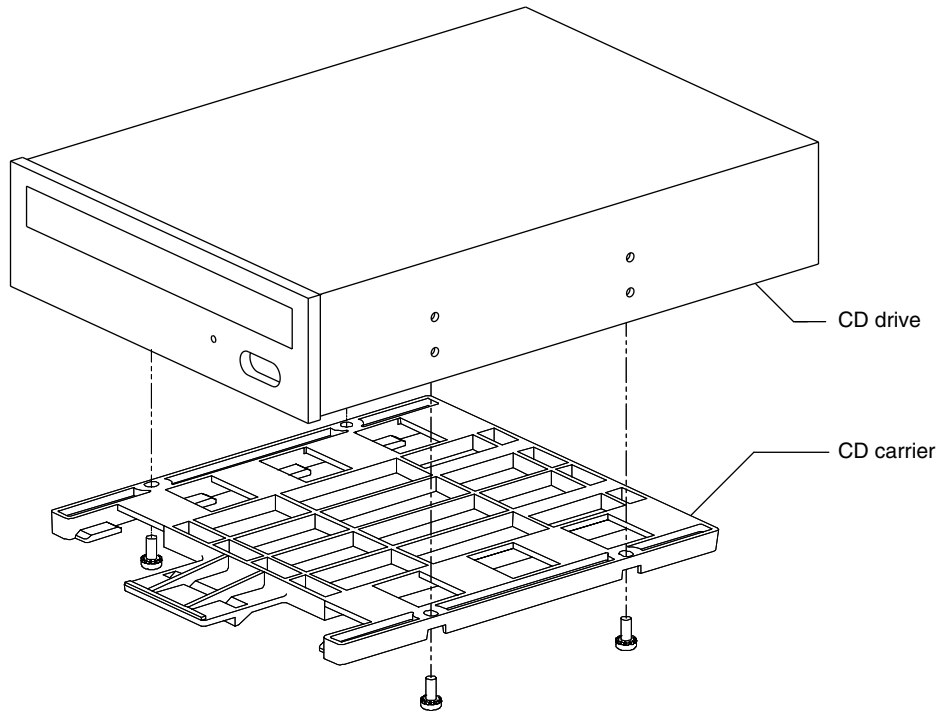

## Power for the CD-ROM Drive

Table 5-1 shows the power budget for the AppleCD 300i CD-ROM drive in the Macintosh LC 575 computer.

**Table 5-1** Power provided for the AppleCD 300i CD-ROM drive

Voltage	Current
+5	500 mA max.
+12	800 mA max., 1.5 A peak (300 ms, 50% duty cycle)

## Internal Storage Devices

**Note**

The AppleCD 300i CD-ROM drive connects to the internal SCSI bus. The drive does not have a SCSI terminator, because the internal SCSI bus is terminated in the built-in hard disk. ♦

## Internal CD-ROM Integration

---

Apple's internal CD-ROM drive uses SCSI ID number 3.

Audio from the CD-ROM is connected to the computer by a separate connector adapter. Figure 5-6 shows the pin assignments. Each channel has its own ground return; the computer's audio circuits have differential inputs. The maximum signal level for the audio is  $0.7\text{ V} \pm 0.1\text{ V RMS}$  at  $47\text{ k}\Omega$ .

**Figure 5-6** Pins on the internal CD-ROM audio connector

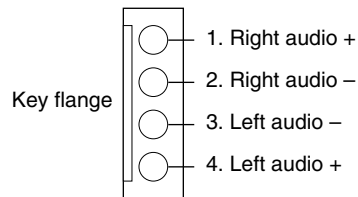



# AppleCD 300i Plus

This appendix describes the performance and capabilities of the AppleCD 300i Plus drive, the internal CD-ROM drive included in some configurations of the Macintosh LC 575 computer.

## General

The AppleCD 300i Plus supports the worldwide standards and specifications for CD-ROM and CD-digital audio discs described in the Sony/Phillips Yellow Book and Red Book. The drive can read CD-ROM, CD-ROM XA, CD-I, and PhotoCD discs as well as play standard audio discs.

The AppleCD 300i Plus has a sliding tray to hold the disc. The drive features a double-speed mechanism that supports sustained data transfer rates of 300 KB per second and data buffer that further enhances performance.

## Specifications

Table A-1 lists the specifications and performance characteristics of the AppleCD 300i Plus drive.

**Table A-1** AppleCD 300i Plus specifications

<b>Physical specification</b>	<b>Value</b>
Depth (excluding bezel)	203.2 mm (8.00 in.)
Width	146.0 mm (5.75 in.)
Height	41.4 mm (1.63 in.)
Weight	1.25 kg (2.75 lb.)
<b>General specification</b>	<b>Value</b>
Spinup time (maximum)	3 sec. (double speed), 2 sec. (normal speed)
Spindown time (maximum)	1.5 sec. (double speed), 1 sec. (normal speed)
Eject time (maximum)	7 sec. (double speed), 6.5 sec. (normal speed)

*continued*

AppleCD 300i Plus

**Table A-1** AppleCD 300i Plus specifications (continued)

<b>CD-ROM specification</b>	<b>Value</b>
Modes supported	CD-ROM (Mode 1 and Mode 2), CD-ROM XA (Mode 2, Form 1 and Form 2), CD-I (Mode 2, Form 1 and Form 2), Photo CD (single session and multisession), and CD audio
Block lengths supported	
CD-ROM Mode 1	2048 bytes
CD-ROM Mode 2	2336 bytes
Blocks per disc	336,150 (typical)
Data capacity	656 MB, Mode 1 748 MB, Mode 2
Address description	Minutes, seconds, blocks
Transfer rate (sustained)	300 KB/sec., Mode 1 (double speed) 150 KB/sec., Mode 1 (normal speed) 342.2 KB/sec., Mode 2 (double speed) 171.1 KB/sec., Mode 2 (normal speed)
Blocks per second	150 (double speed), 75 (normal speed)
Access time (average)	295 ms (double speed), 410 ms (normal speed)
SCSI transfer rate (burst)	2.5 MB/sec., Mode 1 and Mode 2, asynchronous 2.1 MB/sec., Mode 1 and Mode 2, synchronous
SCSI buffer memory	200 KB or 256 KB
<b>CD-audio specification</b>	<b>Value</b>
Block lengths supported	2448, 2368, and 2352 bytes
Playing time	74 min., 42 sec.
Line output	0.7 V RMS at 47 k $\Omega$
Headphone output (front panel)	0.65 V RMS at 32 $\Omega$
Distortion	< 0.04% at 1 kHz
Signal-to-noise ratio	> 80 dB
Frequency response	5 Hz to 20 kHz

# Index

---

## Numerals

---

24-bit addressing 28  
32-bit addressing 28, 35

## A

---

abbreviations xi–xiii  
access to the logic board 4  
ADB (Apple Desktop Bus) ports 17  
ADB controller 28  
address maps 28, 29  
Antelope custom IC 28  
AppleCD 300i 59  
    dimensions of 59  
    specifications of 63  
Apple IIe card 13, 30  
    display for 5  
Apple SuperDrive 15  
automatic termination 15

## B

---

block diagram 25  
booting from CD-ROM 37  
byte steering 27

## C

---

CD-ROM booting 37  
CD-ROM drive 59  
    audio signals from 61  
    connectors on 56  
    dimensions of 59  
    internal audio connector 61  
    mounting sled for 60  
    power for 60  
    SCSI ID number 61  
clock speed 24  
CLUT and DAC IC 28  
color lookup table (CLUT) 28  
communications card 17  
compatibility with PDS cards 51

connector adapters 13, 56  
connectors  
    ADB 17  
    expansion slot 46, 52  
    floppy disk 15  
    hard disk 56  
    I/O, on expansion card 51  
    SCSI 13  
    serial I/O 16  
    sound input jack 18, 39  
    sound output jack 27  
control panels  
    Screen 40  
    Sound 38  
custom ICs  
    Antelope 28  
    DFAC II 27  
    MEMCjr 26  
    PrimeTime 26, 48

## D

---

DFAC II custom IC 27  
display, reactivating after Power Saver 36  
dynamic bus sizing 27

## E

---

Ethernet interface 17  
expansion card  
    address space 30, 52  
    card-select signal 52  
    connector for 52  
    design drawings 69  
    design guidelines 51  
    I/O connector on 51  
    PDS card compatibility 46  
    power 52  
expansion slot 21  
    compatibility with PDS cards 51  
    connector 46  
    MC68030 compatibility 48  
    not a PDS 46  
    pin assignments 46  
    signal descriptions 48

expansion slot (*continued*)  
 signal loading 48  
 similarity to PDS 46  
 SNDOUT pin 48

---

## F

features summary 2  
 floppy disk connector 15

---

## G

gestaltMachineType values 34  
 Gestalt Manager 34  
 GPi (general-purpose input) signal 16

---

## H

hard disk, connector on 56

---

## I, J

installation of storage devices 56  
 interrupts, for the push buttons 36

---

## K, L

keyboard  
 Power key 6, 20  
 reset and NMI functions 20

---

## M, N, O

machine identification 34  
 master power switch 6  
     location of 4  
 MC68HC05 microcontroller 28  
 MC68LC040 microprocessor  
     clock speed 24  
     compared with MC68020 and MC68030 24  
     compared with MC68040 24  
     features of 24  
     upgrading to MC68040 24

MEMCjr custom IC 26  
     compatibility with DAFB IC 26  
     similarity to MEMC IC 26  
 memory control IC. *See* MEMCjr custom IC  
 microphone  
     built-in 18  
     connector for 39  
     power for 18  
 MOVE16 instruction 37

---

## P

parameter RAM 28  
 PDS cards, compatibility with 51  
     *See also* expansion card  
 power, for expansion card 52  
 power, safe shut down 6, 35  
 power for CD-ROM drive 60  
 Power key 6, 20  
 Power Saver 7, 36  
 power switch 6  
     location of 4  
 PrimeTime custom IC 26  
     I/O bus adaptor in 48  
 push button interrupts 36  
 push button register 36  
 push buttons  
     interrupts for 36  
     location of 4  
     screen control 6  
     sound level 6

---

## Q

QuickDraw 37

---

## R

RAM  
     address space 30  
     configurations 7  
     expansion 7  
 RAM SIMMs  
     JEDEC specification for 8  
     mechanical specifications 8  
     pin assignments 8  
     sizes 8  
 reactivating the screen 36  
 removing the logic board 4



ROM software 34–36  
 changes in 34  
 modularity of 34  
 support for ADB 35  
 support for MMU 35  
 support for Power Saver 36  
 support for sound ICs 35  
 support for video ICs 35

## S

---

safe shut down 35  
 Screen control panel 40  
 screen control push buttons 6  
 Screen driver 40–43  
   calls 41–43  
     PBControl call 42  
     PBOpen call 41  
     PBStatus call 42  
 SCSI bus termination 14–15  
 SCSI connector 13  
   adapter for 13  
 serial I/O ports 16  
   modem power 16  
 slot, expansion. *See* expansion slot  
 sound  
   built-in speakers 19  
   filters 20  
   input jack 18  
   microphone 18  
   modes of operation 19  
   output impedance 19  
   output jacks 19, 27  
   playthrough feature 19  
   push buttons 6  
   sample rates 20  
   speakers disconnected 19  
 sound circuits 27  
   buffers 27  
 Sound control panel 38  
 sound input jack 39  
 sound output jacks 19, 27  
 standard abbreviations xi–xiii  
 startup from CD-ROM 37  
 storage devices, installation of 56  
 summary of features 2  
 System 7.1 36  
 system enabler 37  
 system software 36–40  
   enhanced QuickDraw 37  
   new features of 36

## T, U

---

termination of the SCSI bus 14  
 automatic 15

## V, W, X, Y, Z

---

video display 5  
   bits per pixel 12  
   dimming by Power Saver 7  
   for Apple IIe card 5  
   intensity of 6  
   resolution 30  
   timing 30  
 video RAM. *See* VRAM  
 virtual memory 35  
 VRAM 30  
 VRAM SIMMs 12

# Foldouts

---

This appendix contains foldouts of the design drawings for the I/O expansion card described in Chapter 4, “Expansion.”



UNLESS OTHERWISE SPECIFIED

OPTIONAL TOOLING HOLES; IF USED WITH STANDOFF REFER TO APPLE P/N 815-0308.

HOLE RECOMMENDED FOR STANDOFF. REFER TO APPLE P/N 815-0177.

CONNECTOR, STRAIGHT HEADER : 96-PIN; APPLE P/N 515-0860, COMPATIBLE W/ LC FAMILY 120-PIN, APPLE P/N 515-0861; COMPATIBLE W/ LCI) AND SUBSEQUENT VERSIONS.

SHIELD PLATE REQUIRED TO MAINTAIN INTEGRITY OF EMI/RFI SEAM.  
REFER TO APPLE P/N 062-0489.

DO NOT PLACE HOT COMPONENTS IN THIS AREA.

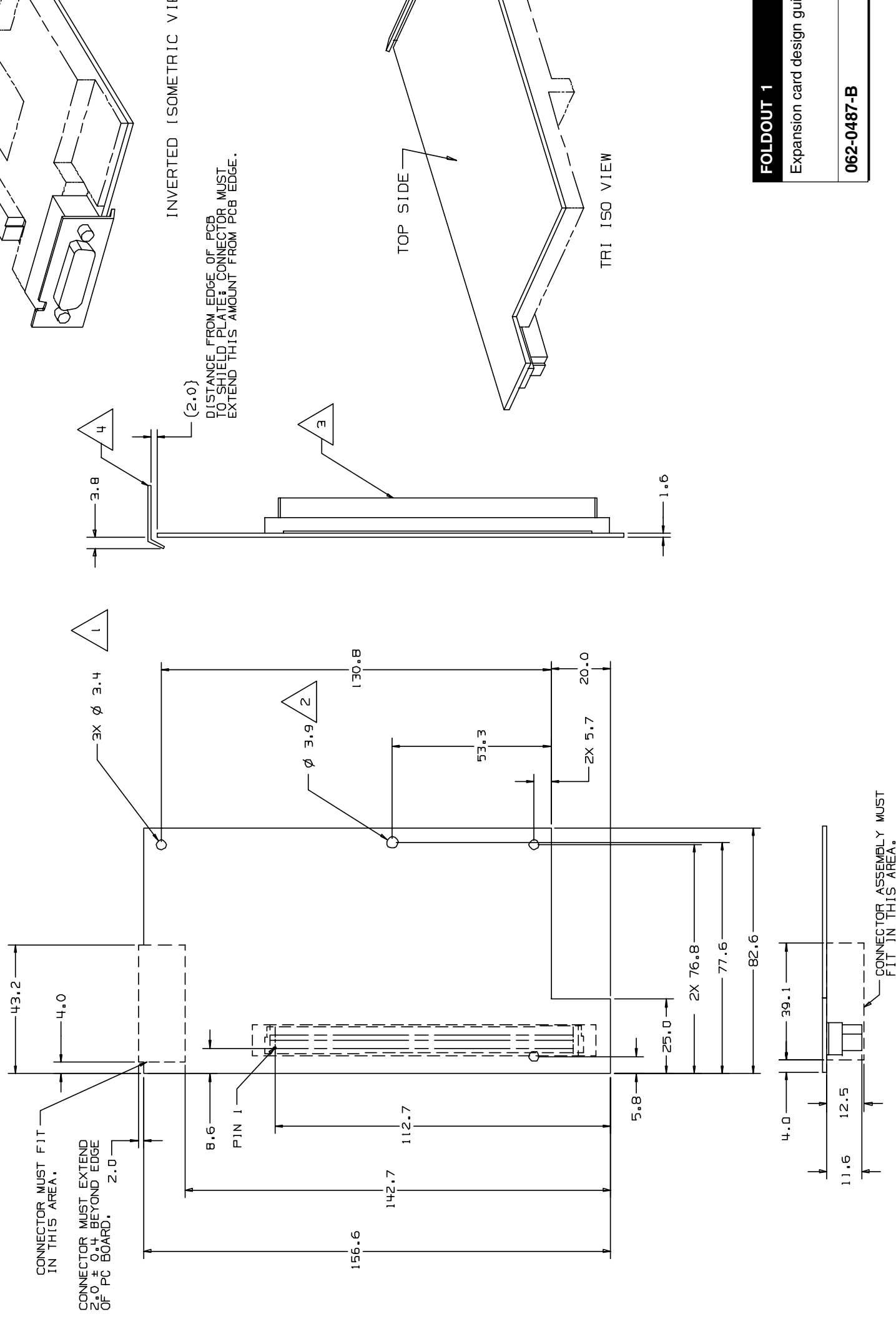

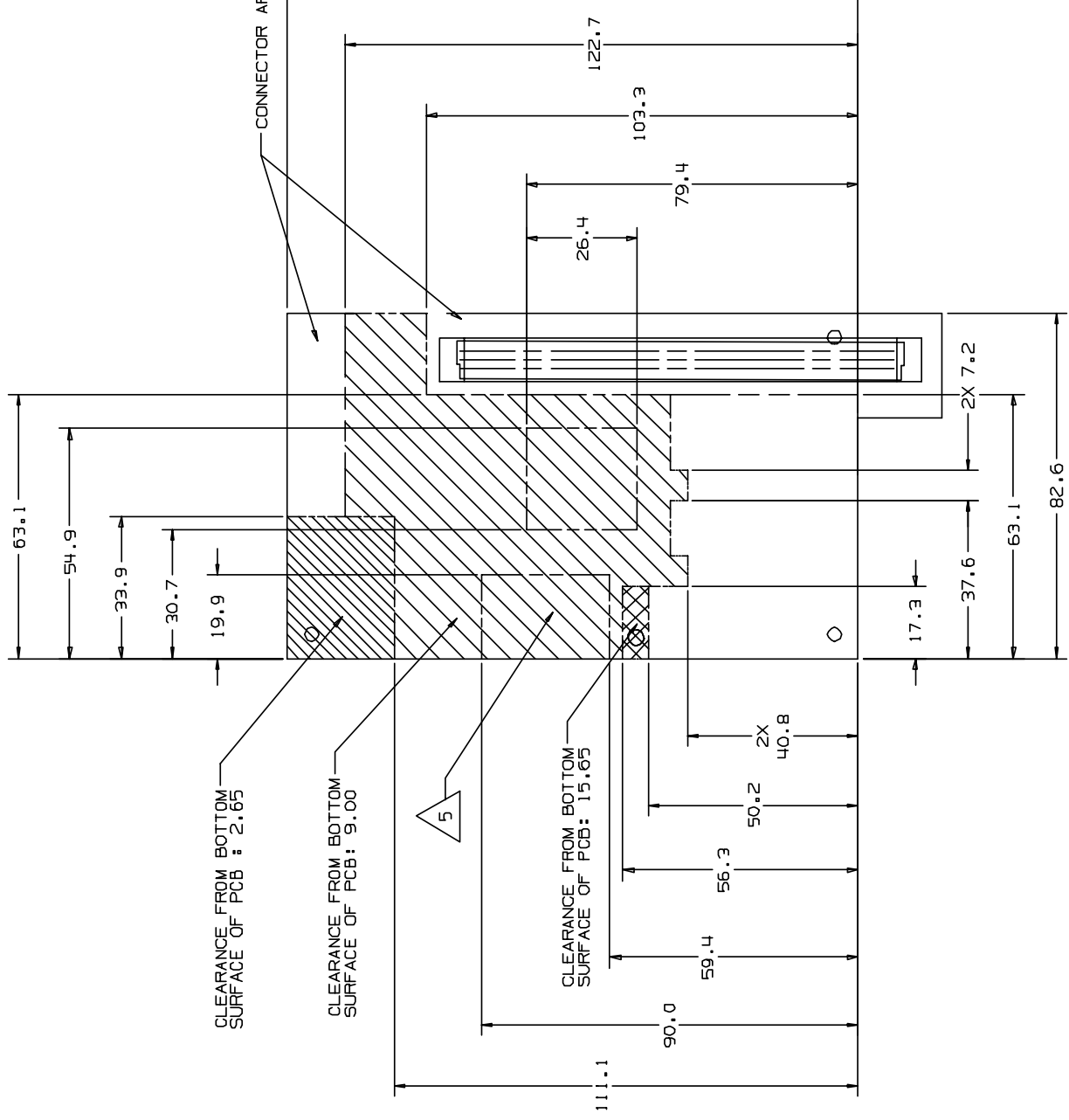

UNLESS NOTED CLEARANCE = 6.25MM

DETAIL **B**

BOTTOM SIDE  
 COMPONENT HEIGHT RESTRICTION ZONES  
 COMPONENT SIDE OF BOARD

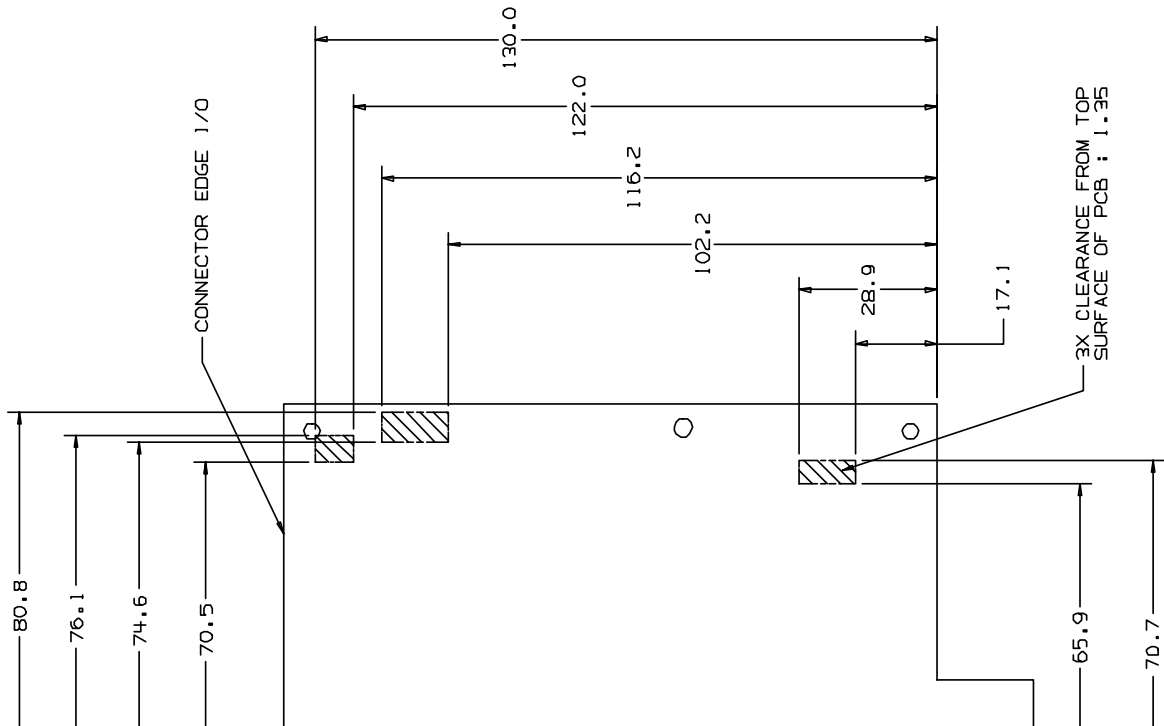

UNLESS NOTED CLEARANCE = 8.0

DETAIL **A**

TOP VIEW  
 COMPONENT HEIGHT RESTRICTION ZONES  
 SOLDER SIDE OF BOARD

FOLDOUT 2

Expansion card component

062-0487-B

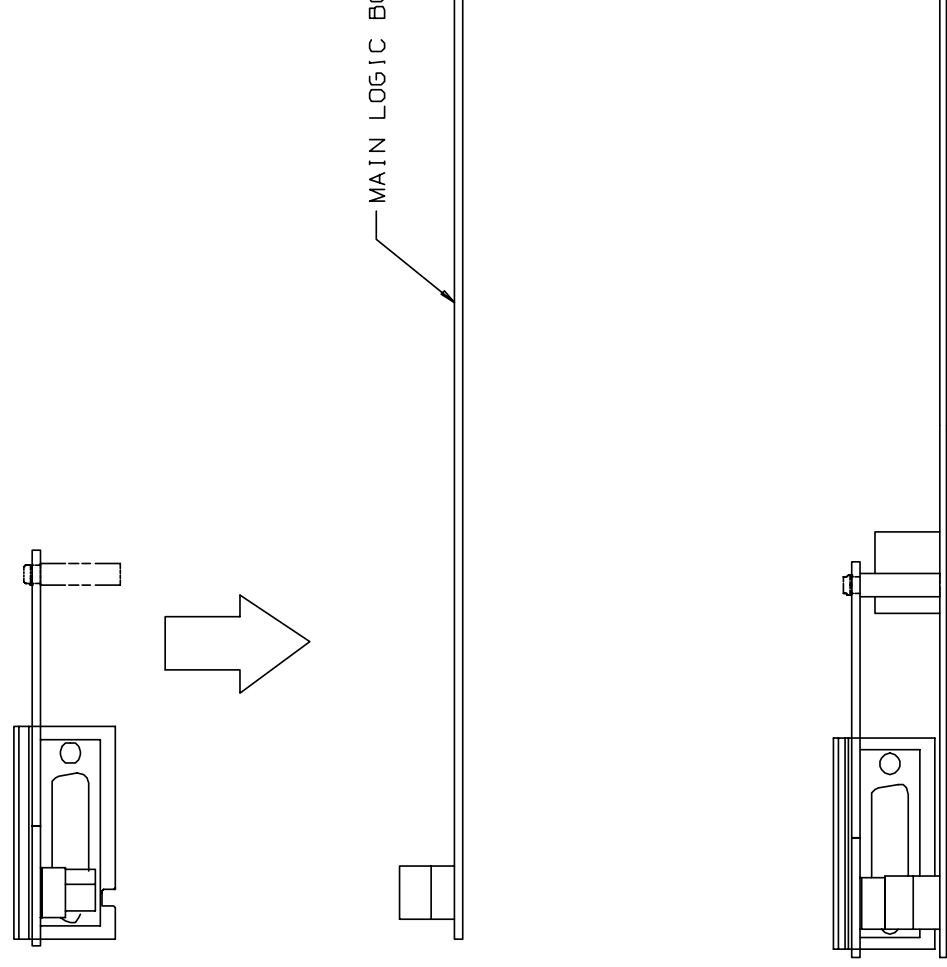
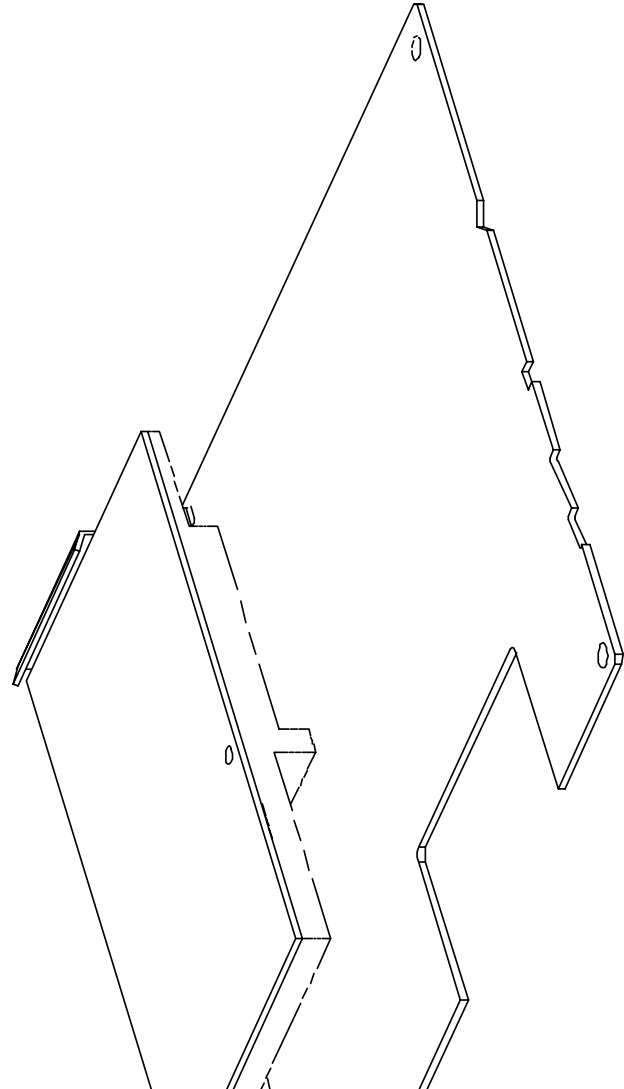
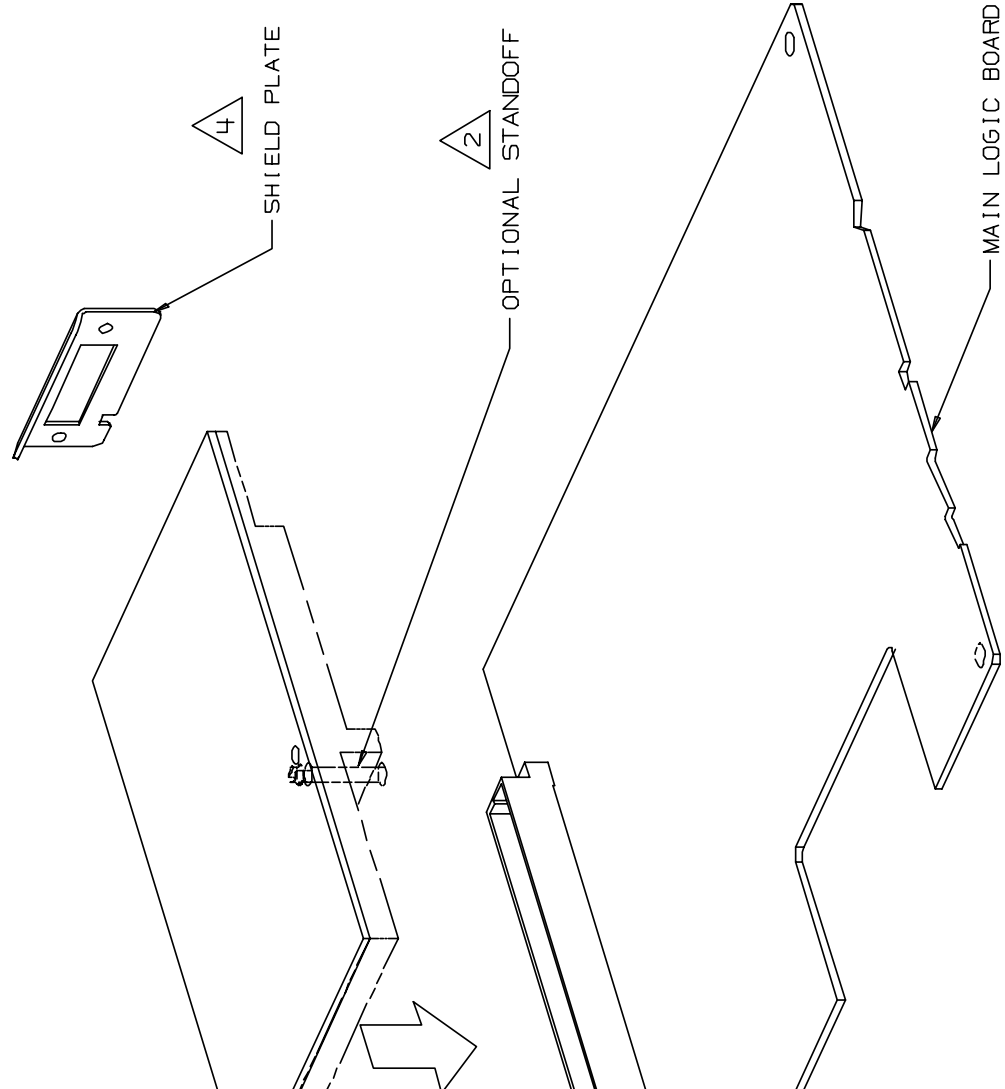

**FOLDOUT 3**

Expansion card assembly

**062-0487-B**